



# Manual

<b>UV-185/5CZ</b>	<b>Ultraviolet flame detector</b>
<b>UV/IR-210/1CZ</b>	<b>Ultraviolet/Infrared flame detector</b>
<b>IR3-109/1CZ</b>	<b>Triple Infrared flame detector</b>





## Contents

1. Safety instructions .....	3
2. Data Sheet .....	4
3. Function of the detector .....	6
3.1 Settings.....	7
4. Installation: Mounting and Orientation.....	7
4.1 General planning guidelines .....	7
4.2 Performance-requirement A, B and C.....	8
4.3 Cone of vision .....	8
4.5 Shadow effect .....	9
4.6 Voting.....	10
4.7 Mounting below a ceiling .....	10
4.8 Weather protection .....	10
5. Mounting.....	10
6. Installation: Electrical .....	11
6.1 Wiring: Fire Control Panel .....	12
6.2 Wiring: PLC.....	13
6.3 Installing the manual self-test .....	14
7. Commissioning and testing.....	14
7.1 Commissioning.....	15
7.2 Testing.....	15
7.3 Failure analysis .....	15
8. Maintenance.....	16
9. Warranty.....	16
9.1 Returns and repairs.....	16
10. Appendices.....	17
10.1 Appendix A: EU-Declaration of Conformity - CPR 305/2011/EU.....	17
10.2 Appendix B: EU-Declaration of Performance - CPR 305/2011/EU.....	18
10.3 Appendix C: EU-Declaration of Conformity - ATEX Directive 2014/34/EU .....	19
10.4 Appendix D: IECEx-Declaration of Conformity - Hazardous Areas.....	20
10.5 Appendix E: North American approvals – cFMus class 3611 & FM class 3260.....	21



Check the website [www.sense-ware.com](http://www.sense-ware.com) for the latest information and latest version of this manual as well as the applicable Declaration(s) of Conformity.

Due to the policy of continued product development SENSE-WARE Fire and Gas Detection BV reserves the right to alter or amend information in their publications without prior notice and no responsibility can be accepted for errors or omissions.



## 1. Safety instructions

Please read this manual carefully and study the cautions, before you start installing or using this equipment. Herewith you ensure a safe and proper use of this equipment. These safety instructions provide important information and must be consulted.

1. Leave the commissioning and maintenance of this equipment to an authorized and qualified electro mechanic.
2. Consult for the electrical installation of this equipment the local and international rules which apply for the country in which the equipment will be used.
3. Install the flame detectors according to the instructions of this manual.
4. Never touch the electric components and printed circuit boards of this equipment. Keep the electrical parts screened during installation, to avoid the risk of an electrical shock.
5. During installation, do not touch the sensors with your bare hands. In case it nevertheless happened, clean the sensors with help of a microfiber cloth.
6. Grounding of the flame detector is not necessary. Install the flame detector and the swivel mount properly to avoid electrical shocks and electrical interference.
7. Do not drill holes in the flame detector housing; holes in the housing damage the ingress protection of the equipment.
8. Use for the cabling of this equipment the pre-mounted cable gland.
9. Connect the equipment according to the safety instructions. Improper use can cause irreversible damage.
10. Make sure that the cover is fully and correctly mounted on the housing before you power up the equipment.
11. Make sure that all cautions are taken before you open the cover. Switch the power off before you open the cover in a hazardous area.
12. Never open the equipment in a situation where hazardous gas or dust is present.
13. When cleaning the swivel mount SM21, exclusively use a damp microfiber cloth to avoid the mount from getting static.
14. Make sure that the users of the installation are well-instructed and know which actions should be taken in case of an alarm.
15. In case of doubt consult the supplier of this product.
16. SENSE-WARE does not take responsibility for the proper working of this equipment, if it is not commissioned or used according to the instructions in this manual.



## 2. Data Sheet

The SENSE-WARE flame detectors utilize a microprocessor for sophisticated electronic signal analysis. The sensors must exceed their alarm threshold to initiate a fire alarm. The UV/IR and IR3 flame detector use as additional alarm criterion: the analysis of the flame flicker-frequency. The UV/IR and IR3 flame detectors have a good false alarms rejection. The UV is insensitive to practically all false alarm sources, except for arc welding. Common applications in which the three 210-series flame detector models can be used can be found in the table below. Visit the website [www.sense-ware.com](http://www.sense-ware.com) if your application is not mentioned in this list.

Application *	UV	UV/IR	IR3
Aircraft hangars		✓	✓✓
Atriums		✓	✓✓
Battery storage rooms / data communication	✓	✓✓	
Biogas		✓	✓✓
Car, bus, tram and train parking's		✓	✓✓
Clean rooms: semi-conductor, pharmaceutical & hospital operating rooms	✓	✓✓	
CNG filling / refilling for buses (public transportation)		✓✓	✓✓
Cold Storages	✓✓		
Conveyer belts			✓✓
Diesel Engine Rooms		✓	✓✓
Electric power transformers		✓✓	✓
Engine test cells / rooms	✓	✓✓	✓✓
Fume hoods	✓✓	✓	
Gas Cabinets	✓	✓✓	✓
Gasoline / Gas Engine Rooms	✓	✓✓	✓✓
Service stations and plug-in (hybrid) charging stations		✓✓	✓✓
Heating Rooms for chemicals	✓✓	✓	
Hydraulics e.g. Extruders		✓	✓✓
Indoor chemical, fuel and solvent storage	✓	✓✓	✓
Indoor Hydrocarbons storage and processing	✓	✓	✓✓
Indoor Hydrogen storage and processing	✓✓	✓✓	
Radio amplifier rooms / Isolators for antennas	✓✓		
Laboratories	✓	✓✓	✓
Loading and unloading terminals: truck, rail, & marine		✓✓	✓✓
Monitoring of machinery	✓	✓✓	✓✓
Outdoor chemical, fuels, paint and solvent storage		✓	✓✓
Outdoor Hydrogen storage and processing		✓✓	
Oil and Gas pipe line and pumping stations		✓	✓✓
Paint spray booths			✓✓
Recycling and waste processing plants		✓	✓✓
Wind Turbines		✓	✓✓

Suitable: ✓ Recommended: ✓✓ \* Please get in contact with your sales representative for applicability

### Features

- Monitors higher hydrocarbons flames (wood, paper, petrol) but also lower hydrocarbons such as methanol and methane.
- The UV and UV/IR flame detectors detect hydrogen flames.
- Good immunity against the influences of:
  - direct and reflected sunlight.
  - artificial light, such as fluorescent tubes and glass covered halogen lamps.
  - arcs and electric discharges (static or from e.g. electric motors).
  - the radiation from arc welding, provided that the distance to the arc welding is >4 m (UV/IR) or >3 m (IR3) from the detector.
- IR3 flame detector is suitable for smoky fires.
- Automatic Sensor Test (Built-in Self-Test) which monitors the sensors and the electronics of the flame detector for its proper operation.
- DIL-switches to set latching/non-latching alarm relay output.



## Benefits

- Rugged sensors make the detector suitable for virtually all fire types.
- Sophisticated software enhances the reliability and availability of the detector.
- Design of the housing and the swivel mount avoid mounting errors with regard to grounding.
- Automatic Sensor Test (Built-in Self-Test) enhances the reliability and availability of the flame detector.
- A Pressure Compensating Element avoids additional cost of maintenance caused by moisture build up and increases life time.
- Nonincendive (non-sparking) design enhances the reliability and the availability and with a reasonable add on price.
- Warranty: whichever comes first: 36 months after installation or 42 months after supply.

## Specifications

Power	12-24 Vdc (10-28 Vdc)
Current normal	25 mA at 24 Vdc
Current in alarm, at 24 Vdc	+/- 75 mA at 24 Vdc
Startup time	<10 sec
Alarm output setting	Selectable LEDs and relays latching/non latching, factory setting: latching
Connection to	-Fire control panels by means of end of line (EOL) and alarm resistor (current increase) -devices that can take relay outputs -PLC's with a 0-20 mA input
End of line and alarm resistor	To be adjusted to the fire control panel, free terminals dedicated to the resistors are available. <b>Remark:</b> the alarm- and EOL resistor must be rated 2 W minimum each and the total power dissipation of both alarm- and EOL resistor should not exceed 2 W.
Relay outputs: -alarm relay -fault relay	De-energized during normal operation, no alarm, SPDT, 30 Vdc – 2 A, 60 W max. Energized during normal operation, no fault, SPDT, 30 Vdc – 2 A, 60 W max.
Current output	Standard available 0-20 mA (stepped, sinking, non-isolated)
Alarm response time	< 10 sec, See appendices.
Cone of vision	90° minimum
Housing	Glass Reinforced Polyester (GRP), Lid screw tightening torque 2 nm minimum.
Ingress protection	IP65
Temperature, operating	-40 °C to +70 °C (-40 °F to +158 °F)
Temperature, ambient	ATEX, IECEx and FM class 3611: -25 °C to +70 °C (-13 °F to +158 °F), see appendixes
Automatic and manual Self-Test	Automatic Sensor Test (Built in Self-Test) and manual self-test
Dimensions	125 x 80 x 57 mm (4.9 x 3.15 x 2.25 inch)
Weight	465 gram (1.05 lbs.)
Cable gland	M20 (cable conduit diameter 5.5-13 mm, two steps 5.5-8 mm and 8-13 mm)
Pressure compensating Element	PCE (Pressure Compensating Element) avoids moisture build up in the detector housing, caused by pressure differences as a consequence of temperature fluctuations.
Terminals	Suitable for solid cores 0.5 to 1.5 mm <sup>2</sup> (20 to 16 AWG), tightening torque 0.4 nm minimum.
EN54-10 Certificate, Performance	UV-185/5CZ and UV/IR-210/1CZ: Class 2. IR3-109/1CZ: Class 1 (see appendix)
ATEX, IECEx Cert., Hazardous Area	II 3G Ex nA IIC T4 Gc, II 3D Ex tc IIIC T 71°C Dc, IP65
FM3260 approval, Performance	(see appendix)
FM3611 approval, Hazardous Area	Nonincendive (non-Sparking), (see appendix)
Optional Swivel Mount SM21 material	PA66, UV resistant; 316 Stainless Steel fixings
Optional Swivel Mount SM21 weight	280 gram (0.62 lbs.)

## Ordering information

Catalog Code	Part #	Description
UV-185/5CZ	SW1110	UV flame detector, EN54-10 certificate, suitable for ATEX zone 2/22, FM3260 and FM3611 approval
UV/IR-210/1CZ	SW1105	UV/IR flame detector, EN54-10 certificate, suitable for ATEX zone 2/22, FM3260 and FM3611 approval
IR3-109/1CZ	SW1138	IR3 flame detector, EN54-10 certificate, suitable for ATEX zone 2/22, FM3260 and FM3611 approval
SM21	SW1131	Swivel Mount
TC-169/1	SW1153	Test lamp for 210 series flame detectors, including univ. charger & carrying case, non EX
TC-940/1Z	SW1120	Test lamp for 210 series flame detectors, including carrying case, intrinsically safe (pending)



### 3. Function of the detector

#### The LEDs on the display

The SENSE-WARE flame detector has 3 LEDs on the display. These have the following meaning:

- continuous green: normal operation
- continuous yellow: fault
- blinking yellow: fault warning and guide to repeat self-test after a self-test or test failure
- continuous red: alarm

#### Normal operation

During normal operation only the green ("powered") LED is turned on.

#### Fire alarm

In case of an alarm the green normal operation LED turns off and the red alarm LED turns on. If the standard setting is active the alarm LED is latched. The latching condition can be reset by powering off the flame detector (approx. 1 sec.). After this the flame detector should be powered up again.

#### Fault

In case of a fault, next to the normal operation LED also the fault LED is turned on. The fault LED doesn't latch. As soon as the fault disappears, the fault LED turns off. In case of a noncritical fault of the flame detector, such as a malfunctioning test source, in case of an alarm situation the yellow fault LED turns off and the red alarm LED turns on. In case the yellow LED is blinking a repeated self-test is activated, after a self-test failure. If the detector does not pass the repeated self-test, the yellow LED will be on continuously.

#### Relay outputs

The flame detector has 2 relay outputs:

- a. alarm relay (SPDT)
- b. fault relay (SPDT)

##### Ad a. alarm relay

The alarm relay is normally de-energized. During an alarm it is energized. The alarm is selectable latching/non-latching with DIL switch 3. The factory setting of the alarm is latching. The latching condition can be reset by powering off (approx. 1 sec.) the flame detector. After the reset the flame detector must be powered up again.

##### Ad b. fault relay

The fault relay is energized when powered up and will be de-energized in case of a fault. The fault relay is non-latching.

#### 0-20 mA analog output (stepped, sinking, non-isolated)

The 0-20 mA output has the following possible values:

- 0 mA power fault / microprocessor fault
- 2 mA optical fault
- 4 mA normal operation
- 20 mA alarm

In case of a fault, for example because of a defect test source (2 mA) and the flame detector detects a fire, then the current will be switched to 20 mA.

#### Automatic self-test

During the start-up of the flame detector the 3 LEDs will turn on sequentially and the initial self-test is executed. Within 10 seconds the green, yellow and the red LED will turn off and the green LED turns on continuously. After the initial self-test, periodically an optical self-test is executed to monitor the electronics and the sensor(s). During the automatic self-test which takes a few seconds, the outputs of the flame detector are temporary idled. If the sensor(s) fail(s) during the self-test, then the test is repeated several times. If after the repeated self-tests the fault condition remains, the yellow fault LED will turn on steady and the fault relay will de-energize.

#### Manual self-test

The flame detector can test the sensor(s) and also the signal processing with help of the manual self-test. During a successful manual self-test the alarm relay is energized and the red alarm LED turns on. If the detector is in latched condition, the alarm maintains until the detector is powered off. For the manual self-test a switch can be mounted in the alarm panel or PLC. During commissioning this option can be used by connecting terminal 14 with terminal 1 during 5 seconds.



**Remarks:**

1. **Caution:** during a manual optical self-test, the alarm relay is energized, when the test is successful. Make sure that before you start a manual self-test the outputs of the control panel or PLC are disconnected. Reconnect the outputs after you have finalized the self-test.
2. Wiring the manual self-test is explained in the section electrical installation.
3. The manual self-test can be used during commissioning to test the detector without the necessity to use a flame detector test lamp.
4. The manual self-test is not a replacement for the functional test with help of a test lamp. After the commissioning is completed, the flame detectors must be functionally tested by means of a test lamp.

### 3.1 Settings

The flame detector has DIL switches for setting the latching or unlatching mode of the flame detector.

**Remarks:**

1. DIL switches 1, 2 and 4 are not in use.
2. The white rockers of the DIL switches are shown in black in the figures.

In the next table you will find the DIL switch settings for sensitivity and for latching/unlatching settings:

Latching/ Non latching	
Latching (factory setting)	Non latching
<p style="text-align: center;">ON</p> <p style="text-align: center;">1 2 3 4</p> <p style="text-align: center;">DIL 3 on</p>	<p style="text-align: center;">ON</p> <p style="text-align: center;">1 2 3 4</p> <p style="text-align: center;">DIL3 off</p>



**Remarks:**

The factory setting for latching/unlatching is in the "latching" position. The detector must be reset by powering off the flame detector during at least 1 second. This setting is standard for fire control panels in conformity with the European standard EN54. In several industrial applications the unlatching mode can be practical, because the alarm is taken over by the control panel. In that case there is no need to reset the detector by powering it off.

## 4. Installation: Mounting and Orientation

In this chapter a number of general planning guidelines are given for the flame detector system design. Several of these guidelines are discussed in more detail in the next sections.

### 4.1 General planning guidelines

1. A flame detector is a detector which is suitable for fast detection of open fires. These are typically fluid and gas fires but can also be solids such as paper or wood.
2. Flame detectors are "line of sight" detectors. The flame detectors should all have an un-obscured view to monitor the fire risks.
3. Define a performance requirement before starting flame detector system design. For example: the fire must be in the central axis of the flame detector to detect an n-heptane fire of 33 x 33 cm at a distance 15 m within 30 seconds.
4. Identify the fire risks and make sure that a sufficient amount of detectors is installed to monitor all fire risks.
5. Classify, if applicable, the fire risk into the performance requirement classes A, B and C. On the website [www.sense-ware.com](http://www.sense-ware.com) this classification is explained. See also section 4.2.
6. Plan the flame detectors (in quantity and in location), taking the cone of vision of 90° and the range of the detector into consideration.
7. The flame detector must be mounted on a rigid low vibration surface.



8. In indoor applications the flame detector must be placed at approx. 1.5 m (IR3 model ) or 0.5 m (UV and UV/IR moedels) below the ceiling to avoid obscuration by smoke.
9. Extremely tight fog or heavy rains or snow can negatively influence the performance of the flame detector.
10. Make sure that the flame detectors do not monitor potential false alarm sources, which are related to the production process. (for example a flare). Screen, if necessary, the flame detector with help of a plate of 30 x 30 cm.
11. For weather protection of the flame detector (against rain and snow), a plate of 30 x 30 cm can be placed on top of the flame detector if necessary, without negatively influencing the field of view of the flame detector.
12. In outdoor applications and in indoor application (with the exception of ceiling mounting), always mount the flame detectors in such a way that are aligned to the bottom with an angle of 45°.
13. Two detector dependency is unnecessary for a multi criteria flame detector because more than one criteria must be met before a flame detector creates an alarm output. This is not applicable for UV flame detectors. If, nevertheless, two detector dependency or 2 group dependency is required, make use of the "voting-system". See section 4.6.

## 4.2 Performance-requirement A, B and C

Risk class	Risk	Probability and effect	Fire size
A	High	Relatively high probability. Relatively high effect	e.g. 30 x 30 cm n-Heptane *)
B	Medium	Medium probability. Medium effect	e.g. 50 x 50 cm n-Heptane *)
C	Low	Relatively low probability, relatively low effect	e.g. 100 x 100 cm n-Heptane *)

\*) **Remark:** the fuel depends on the application. If a gas fire with non-hydro carbon is expected, it is more useful to define a fire size with a hydrogen plume. For a fire with a light hydrocarbon, a methanol pan fire.

## 4.3 Cone of vision

Consider that the flame detector has a cone of vision of at least 90°.





## 4.4 Orientation

By mounting the flame detector with an angle of  $45^\circ$  heading to the bottom, you make full use of the cone of vision of the flame detector. If, seeing from the top, the flame detector also is directed diagonally, a volume is monitored.

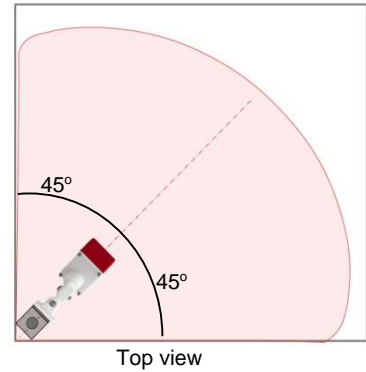
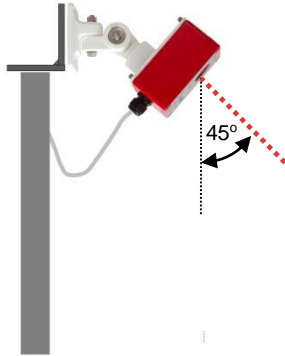

Top view

## 4.5 Shadow effect

As rule of thumb you can take that the mounting height ( $h_d$ ) of the flame detector should be twice the height ( $h_o$ ) of the highest object in the monitored zone.

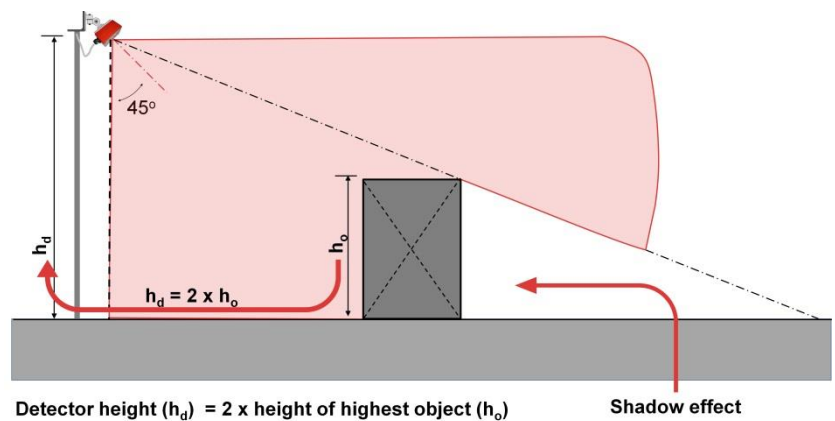

To avoid the shadow effect (in zones which are relevant but which cannot fully be monitored by one flame detector), it is recommendable to place a second flame detector in the opposite corner.

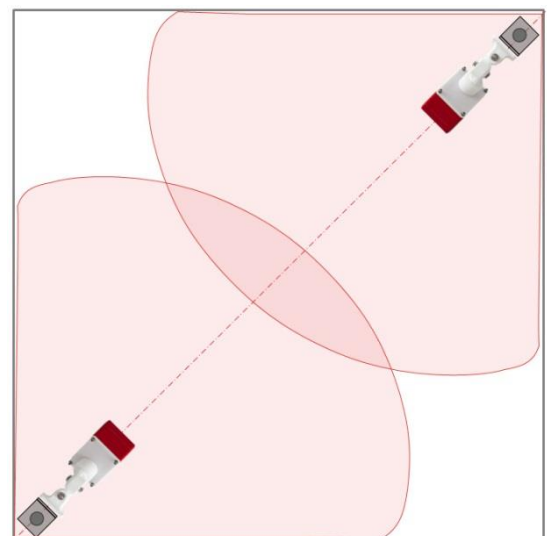



## 4.6 Voting

The flame detector will not give an alarm until several alarm criteria are met at the same time. The probability of a false alarm is therefore very low. The flame detector is for this reason suitable for an extinguishing action based on the signal of one flame detector.

Nevertheless “voting” may be demanded in a functional specification. In that case the “voting-system” may be applied. I.e., the flame detectors may be mounted in the configuration as shown on the right side of this page. Use voting of 2 out of 4 flame detectors should give an alarm before the (extinguishing) output is given. This is the correct approach for voting. Note that the fire control panel or PLC must be suitable for the two detector dependency voting system.

### Remarks

**Caution:** A flame detector is a line of sight detector. Voting with just two flame detectors is not suitable. The redundant flame detector in the opposite corner cannot be used for a 2 detector dependent output, because the shadow effect obscures the free view of the 2nd flame detector. The second flame detector will give an alarm in a later stage or not at all.

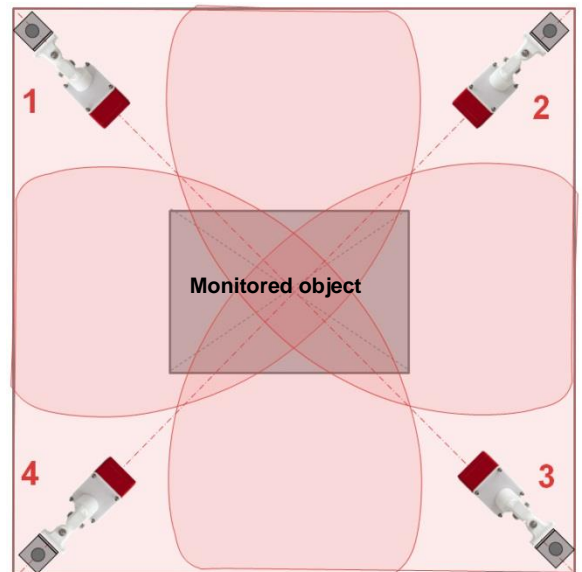

## 4.7 Mounting below a ceiling

Smoke absorbs the radiation of flames. This decreases the sensitivity of the flame detector. UV/IR or UV flame detector. Clearance below the ceiling. C = 1.5 m (60 inch). IR3 flame detector: Clearance below the ceiling. C = 0.5 m (20 inch).

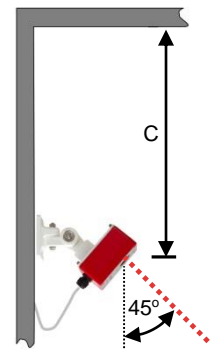

## 4.8 Weather protection

In dirty or wet applications, it is recommendable to place a hood on top of the flame detector. A stainless steel metal plate of approximately 30 x 30 cm (1 sqft) can be mounted directly on top of the flame detector, without inhibiting the cone of vision of the flame detector. A similar plate can be used to protect against potential false alarm sources of friendly fires, such as flares.

## 5. Mounting

For the mounting of the flame detector there are 2 options:

- Mounting with help of the optional swivel mount SM21, (see the separate SM21 manual).
- Mounting on a ceiling (for example in a fume hood of a laboratory or in an engine room of a vessel).

For option b. you need the hole pattern, shown on the right side of this page (shown in mm).

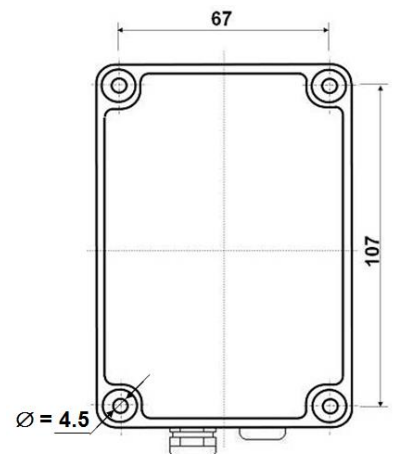



## Remarks:

1. With the optional SM21 swivel mount a convenient alignment of the flame detector on the fire risk is possible.
2. SENSE-WARE strongly recommends applying the SM21 swivel mount.

## 6. Installation: Electrical

The flame detector has several wiring options; the most important are:

- a. Wiring to a fire control panel by means of the current increase principle.
- b. Wiring to a PLC by means of a 0-20 mA current output.
- c. Wiring with an additional manual sensor self-test.
- d. Stand-alone wiring, with direct use of the relays.

The options a to c are explained in this manual. Option d can be directly seen in the electrical connection diagram.

Besides these options (at request) it is possible to:

- a. Use a sourcing instead of a sinking line for the 0-20 mA output to a PLC.
- b. Make use of an address unit of a fire control system.
- c. Use a bus protocol.

For these options dedicated junction boxes are available. Please contact your supplier or SENSE-WARE for these special options.

### Steps for wiring on a fire control panel or a PLC:

1. For the cabling at least 3- or 4 wire cabling is needed, depending on the panel and the type of connection.
2. Use shielded, twisted pairs cable.
3. The diameter of the wires must be 0.5 to 1.5 mm<sup>2</sup> (20 to 16 AWG).
4. The wires must be shielded and there must be a ground wire for connection to the safety ground of the fire control panel or PLC.
5. The isolation resistance to ground must be at least 500K Ohm.
6. The length and diameter of the wires should be selected so that the flame detector will have sufficient power under all conditions (normal and alarm), to make sure that the working voltage is never below 10 Vdc, especially not in the case of an alarm.
7. On the flame detector side of the cable leave a loop of spare cable with a diameter of +/- 10 cm (4 inch).
8. Use for the wiring under the terminals, when needed, tweezers or flat nose pliers.
9. Grounding on the control panel or PLC side: make sure that the wires stay protected as well as possible by the earth screen. Isolate, when necessary, the earth screen and connect it to the safety ground of the panel.
10. Grounding on the flame detector side: make sure that the wires keep protected as well as possible by the earth screen. Cut the earth screen short and isolate it, to ensure that the screen cannot make an electrical connection with ground and with the electronics in the detector housing. Make sure that the electronics in the flame detector housing is isolated from local ground to avoid potential differences (ground loops).
11. Do not connect more than one flame detector per zone.

### Remarks:

- a. Proper shielding is important for the performance of the flame detector and the safety of the equipment.
- b. The flame detector has a non-metal housing and does not have a ground lug. Thus local grounding of the housing is **not** necessary.

The flame detector has a cable gland with an insert included. Use the cable gland with the insert included for cables from 5.5 - 8 mm. Remove the insert for cables with a diameter of 8 - 13 mm.

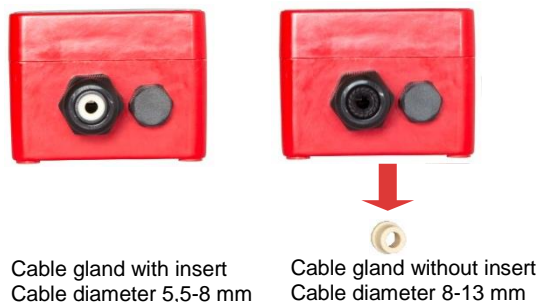



**Power on, no fault**

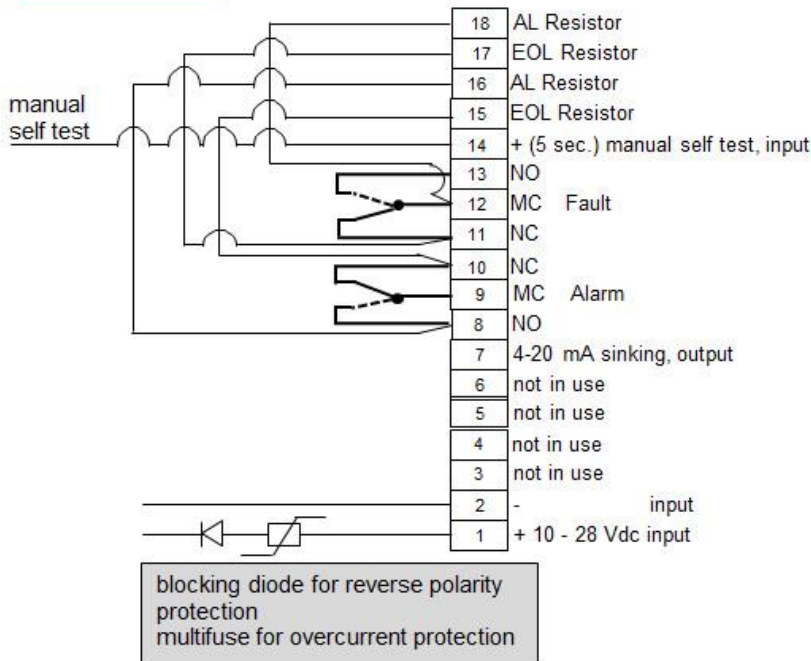

Connection diagram

## 6.1 Wiring: Fire Control Panel

The flame detector can be electrically connected to a fire control panel the same way that a manual call point is connected; by means of the current increase principle. The flame detector is connected to the fire panel with 3 or 4 wire cables. 2 wires for the power supply and 1 or 2 wires for the zone. Optionally an additional wire for the manual self-test (see section 6.3).

The end of line resistor (EOL) is placed between the terminals 15 and 17. The alarm resistor (AL) is placed between the terminals 16 and 18. The end of line- and alarm resistor should be adapted to the fire control panel. It are approximately the same resistors which are also used for connecting a manual call point to a fire control panel.

**Connection diagram**

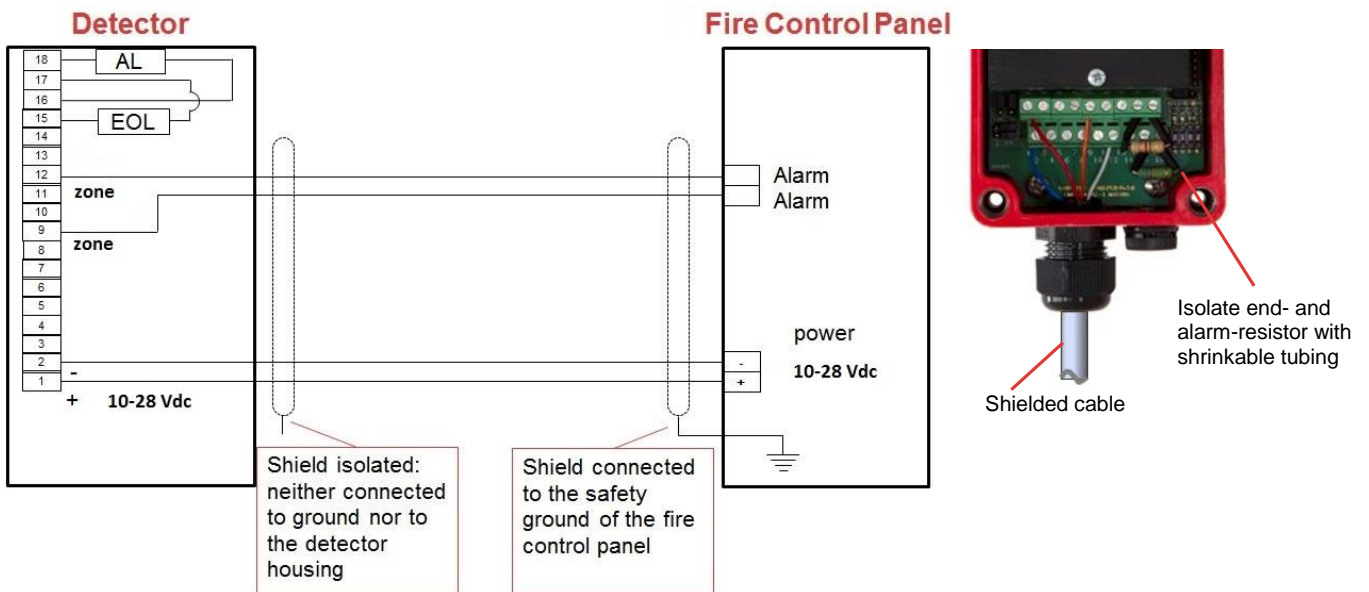



**Principle:**

The zone uses the alarm contact and the fault contact of the flame detector plus resistors. In case of a detector fault a wire breakage is simulated. In case of a fault followed by an alarm, a current  $V_n/AL$  is flowing through the zone. Thus an alarm "overrides" a fault signal, as can be seen in the figure.

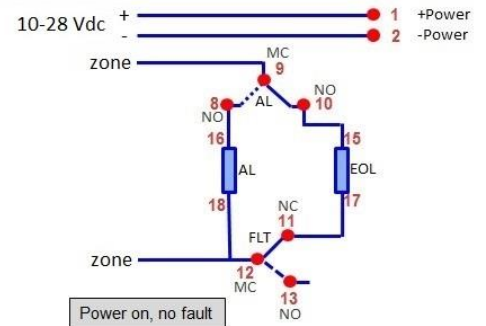

**Remarks:**

1. Normally, the substitution resistance can be compared to connecting a conventional manual call point:  $1/R_{subst} = 1/EOL + 1/AL$ . However, in the shown diagram the substitution resistance is  $R_{subst} = AL$ , because it is only switched over the resistor AL. Because  $EOL \gg AL$  the value will be kept within the tolerances. Please consult the manufacturer of the fire control panel for the values of the resistors.
2. The alarm- and EOL resistor must be rated 2 W minimum each and the total power dissipation of both alarm- and EOL resistor should not exceed 2 W. Use heat shrink tubing to isolate the metal parts of the EOL and the AL resistor.
3. Do not connect more than one flame detector to a zone.

**6.2 Wiring: PLC**

**Connection diagram**

0-20 mA sinking analog output, non-isolated

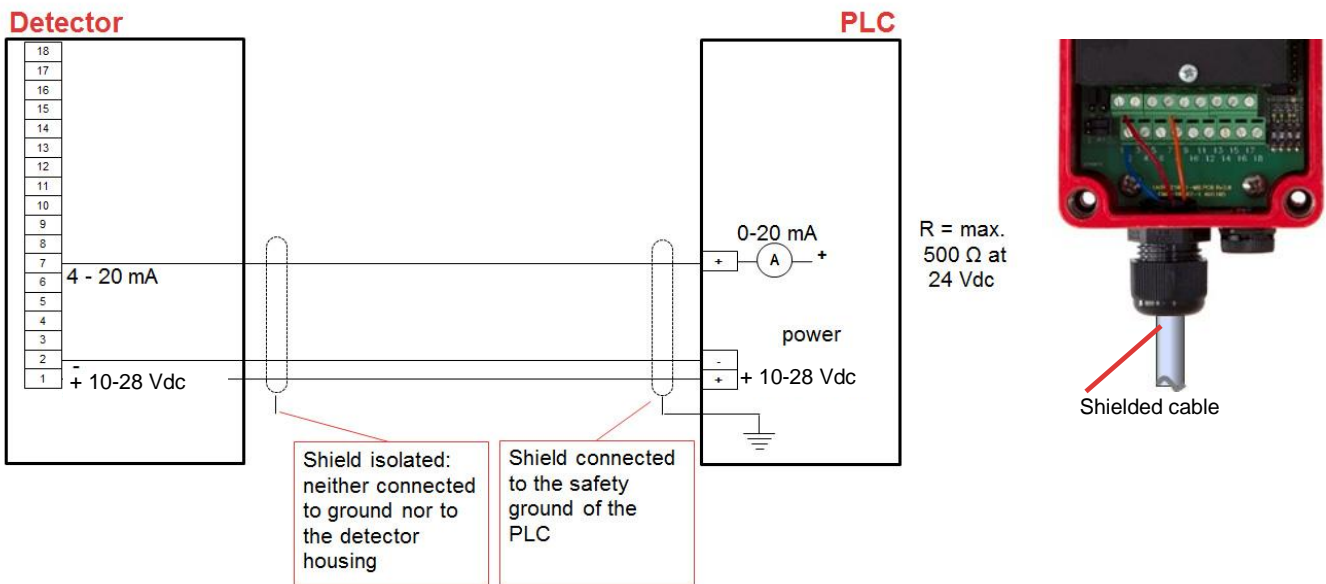

**Remarks**

1. Refer to chapter 3 of this manual for the meaning of the several current levels.
2. Optional, a sourcing analog output is available as a separate junction box.



## 6.3 Installing the manual self-test

For the installation of the manual self-test in this section, 4 options are shown by means of a scheme:

1. Flame detector connected to a fire control panel, with a self-test switch on the fire control panel.
2. Flame detector connected to a fire control panel with a separate switch for the manual self-test.
3. Flame detector connected to a PLC with a self-test switch on the PLC.
4. Flame detector connected to a PLC with a separate switch for the manual self-test.

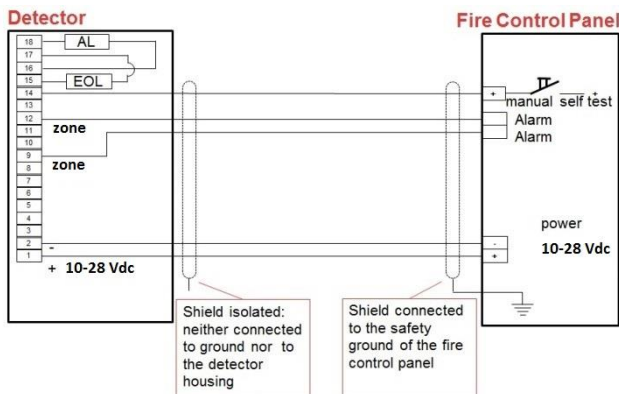

option 1

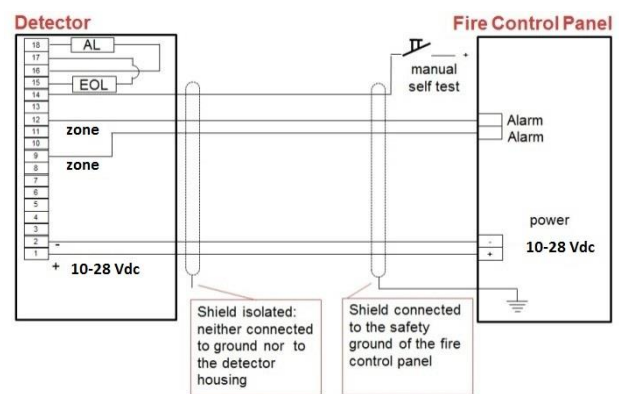

option 2

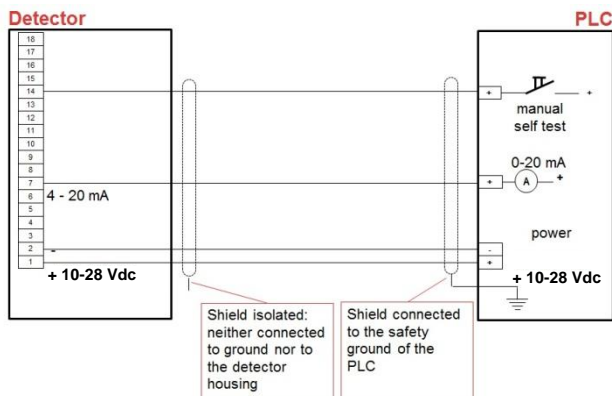

option 3

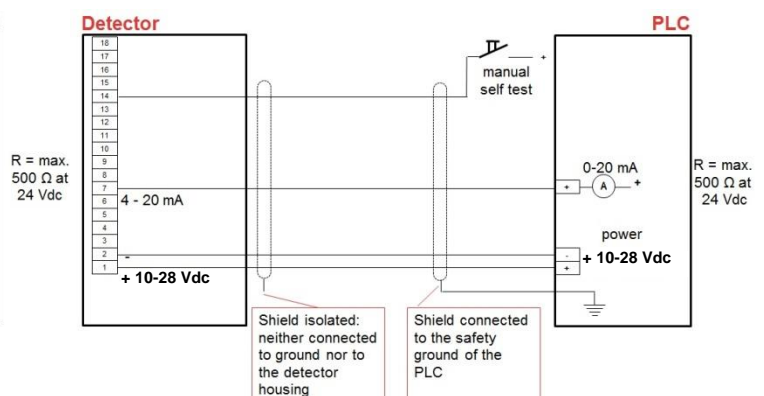

option 4

## 7. Commissioning and testing

### Remarks:

1. The commissioning, maintenance and functional testing of the set-up must be done by skilled and authorized technicians.
2. All local laws and regulations for the commissioning and the cabling apply, including law and regulations for activating alarm systems, extinguishing systems and other outputs.
3. For hazardous area applications appropriate regulations should be followed.
4. UV sensors are based on a Geiger-Muller counting tube, which is also applied for sensing radioactivity. If in your application an alarm is generated, coming from the UV sensor, while the detector window is covered and the cabling/electronics are fault free, this is possibly caused by increased radioactivity. Please consult your supplier for a possible solution.
5. If a sudden strong IR radiation source is placed in the surroundings of the flame detector, the IR sensor(s) can become saturated. Make sure that strong IR radiation sources are kept out of the sight of the flame detector. As soon as the source is removed, the flame detector recovers within 10 seconds to its normal performance.
6. Flame detectors have their strengths and weaknesses. Take that into consideration before you start to install this type of flame detector.



## 7.1 Commissioning

Before the flame detector is activated, the following steps must be executed:

1. Clean the detector window.
2. Close the housing of the flame detector.
3. Check the position and the alignment of the flame detector.
4. Check if there are potential false alarm sources in the sight of the flame detector.
5. Check if this is a correct and valuable application for a flame detector.
6. Check the cabling in between the flame detector and the fire control panel or PLC.
7. Check the shield of the cabling.
8. Check the grounding of the fire control panel or PLC.
9. Check the ingress protection and the cable gland.
10. Thoroughly tighten all fasteners.
11. Thoroughly tighten the cable gland.
12. Perform a functional test with a test lamp.

Before the final commissioning is done, the flame detector should be in use with idled outputs of the fire control panel or PLC for a time which should represent the normal operating conditions. During the test mode the set-up should be checked and, if needed, modified, until all flame detectors are showing a fault free operation. After a final functional test with help of a test lamp, the commissioning can be finalized.

## 7.2 Testing

The flame detector has been tested in the factory. However, the flame detector should be regularly functionally tested in an “end-to-end” test to make sure that the combination of the flame detector and panel responds properly to a fire. The detector window should be clean. A layer of contamination, fat, oil or water lowers the sensitivity of the flame detector.

If the user defined a performance-requirement, with the help of a test fire it can be tested if the requirements are met. For a test fire, the right fuel, the right fire size, the right detection distance should be chosen and also possible additional requirements should be considered. Make sure that before and during the test fire all necessary safety precautions are taken, to avoid harm on persons and damage of goods, caused by the test fire.

SENSE-WARE supplies a test lamp. This test lamp is suitable for functional testing the flame detector. Read the test lamp instructions before you start the functional test.

## 7.3 Failure analysis

False alarms may occur because of the following causes:

1. The flame detector is activated by a known or unknown source in the sight of the flame detector.
2. The flame detector is activated by electromagnetic interference on the cabling and/or on the electronics.
3. The flame detector is activated by wrong or damaged cabling.
4. The electronics of the flame detector is damaged.

For fault finding it is necessary to thoroughly search the root cause of the false alarm or fault and of the circumstances during the false alarm or fault. For example time, date, weather conditions are important features for determining the cause of a false alarm or fault.

### Remarks

If you ask for the support of SENSE-WARE, make sure that you well-reported the fault in the log.

First of all the power supply should be checked: voltage, current, ripples on the voltage signal etc. Next check all items mentioned in the section Commissioning. Exchange, if possible, the flame detector with a spare flame detector or exchange the detector with a flame detector on the site, which is working properly, if the set up contains more than one flame detector.

To determine if the false alarm is caused by an event in the field of view of the flame detector, the flame detector window should be covered. Make sure that no light or other radiation can reach the sensors of the flame detector. If the flame detector is still generating a false alarm, it may be caused by the cabling or by the electronics. Make sure that after the test the detector window is uncovered again.



## 8. Maintenance

Except for cleaning there is no specific preventive maintenance needed. Inspection of the following items is necessary:

1. Check the position and the alignment of the flame detectors.
2. Check if there are no potential false alarm sources in the sight of the flame detector.
3. Check if there are no obstacles which restrict the sight of the flame detectors.
4. Clean the detector window with a micro fiber cloth.
5. Close the flame detector housing. **Remark:** Make sure that the cover of the housing (with detector window) is mounted correctly on the housing. The sensors must be visible when you look through the detector window.
6. Check if the cabling from the flame detectors to the fire control panel or PLC is intact.
7. Check the condition of the cable shielding of the cabling.
8. Check if the earth screen of the cabling on the fire control panel or the PLC side is correctly connected to the safety ground of the panel.
9. Check if earth screen of the cabling on the detector side is correctly isolated, so that there is neither an electrical connection to ground, nor to the electronics in the housing.
10. Check the ingress protection of the cover and the gland so that the detector is dust-proof and waterproof.
11. Check if all fasteners and the cable gland are tightened.
12. Make sure that once a year the inner side of the detector window is cleaned. (for example during a routine-inspection). Particles of the electronics might evaporate and might deposit on the detector window.
13. Perform a functional test with help of a SENSE-WARE test lamp.

**Warning:** Static Electricity Hazard when cleaning the housing and swivel!

Using a dry cloth to clean the housing may cause static discharges which could result in an explosion in an explosive atmosphere. To prevent a static arc, use a clean, damp cloth (slightly wet with water) to clean the housing in hazardous areas. The flame detector window should be cleaned with a dry micro fiber cloth.

### Remarks:

1. The user is responsible for keeping the equipment in optimal condition. If there are any conditions which change the assumptions of the safety set up, be sure that the responsible technician will take the necessary update actions.
2. Never clean the flame detector with a cleaning agent that contains silicones. Silicones absorb UV radiation and therewith make the flame detector less sensitive. Silicones also make the surface more sensitive for contamination.
3. Do not use a liquid cleaning agent for cleaning the flame detector.
4. SENSE-WARE recommends keeping 10% of the same type as the flame detectors in use as spare flame detector or at least one unit.

## 9. Warranty

In the Warranty arrangement the conditions that apply for the SENSE-WARE flame detector are mentioned. If not explicitly mentioned in this manual, the Orgalime S2012 delivery terms and conditions apply.

SENSE-WARE provides for the flame detector a warranty of 36 months after commissioning or 42 months after supply, for defects in the material, considering normal use and maintenance. SENSE-WARE will, under these circumstances and during the warranty period, repair and replace parts, free of charge of products which are returned according to the instructions of this warranty section. All replaced parts become property of SENSE-WARE. The warranty is only valid for companies which directly purchased the goods from SENSE-WARE and cannot be transferred to other parties.

From the warranty are excluded:

1. Defects which are caused by improper use, an incident or lack of maintenance.
2. Defects or damages which are caused by improper commissioning or manipulating the hardware and/or software, applying the wrong operating voltage, water damage etc., or wrongly executed repairs and repairs with non-genuine spare parts.
3. Products from which the serial number is removed or unreadable.
4. Normal wear and tear, including cosmetic damage.

### 9.1 Returns and repairs

1. Ask via your supplier for a SENSE-WARE RMA (Returned Material Authorization). For returns to the factory an RMA is always required.
2. You will get an RMI (Returned Material Information) fill-in form on which you or your supplier fills in the SENSE-WARE invoice number, the serial number and the type of fault.
3. In case of an authorization SENSE-WARE will provide your supplier an RMA number which you have to add to the packing list of the return shipment. You also have to include the RMI form in the shipment plus faxing or emailing it to SENSE-WARE.
4. The shipping cost to and from SENSE-WARE is on the buyer (supplier).
5. Make sure that the flame detector is packed thoroughly before you return it to SENSE-WARE.
6. In case you did not buy the flame detector directly from SENSE-WARE please contact your supplier for an RMA.
7. For goods with an RMI, which require a repair within the warranty period, you can request SENSE-WARE an "advance replacement" via your supplier.

### Remark:

The flame detector does not contain parts which are suitable for a local or field repair.





## 10. Appendices

### 10.1 Appendix A: EU-Declaration of Conformity

In accordance with EN/ISO/IEC 17050-1:2010

**Manufacturer:** Sense-WARE Fire and Gas Detection B.V.  
Storkstraat 7, NL- 3905 KX Veenendaal, the Netherlands, EU

**Declaration:** This declaration of conformity is issued under the sole responsibility of the manufacturer.

**Description:** UV, UV/IR and IR3 flame detectors

**Brand Name:** SENSE-WARE

**Model:** UV-185/5(CZ), UV/IR-210/1(CZ) and IR3-109/1(CZ)

**Intended use:** Flame detectors for use in fire detection and fire alarm systems installed in and around buildings.

We here declare that the product(s) identified above meet(s) the requirements of the following EC Directives and therefore qualifies for free movement within markets comprising the European Union (EU) and the European Economic Area (EEA):

#### **Construction Products Regulation (CPR) 305/2011/EU**

Notified Body: SKG-IKOB  
Notified Body number: 0960  
EC certificate number: 0960-CPR-SKG.1388.3643  
Conforms to: EN54-10: 2002/A1: 2005, Flame detector – Point Detectors

The applicable flame detector(s), for this manual as mentioned in the certificate above, are:

Article	Specification	Classification
UV-185/5(CZ)	Ultraviolet Flame Detector	Class 2
UV/IR-210/1(CZ)	Ultraviolet/Infrared Flame Detector	Class 2
IR3-109/1(CZ)	Triple Infrared Flame Detector	Class 1

#### **EMC Directive 2014/30/EU**

Conforms to: EN 50130-4:2011

Alarm systems – Part 4: Electromagnetic compatibility – Product family standard: Immunity requirements for components of fire, intruder, hold up, CCTV, access control and social alarm systems

#### **RoHS2 Directive 2011/65/EU**

Conforms to: EN 50581:2012

Technical documentation for the assessment of electrical and electronic products with respect to the restriction of hazardous substances.

Signed for and on behalf of the manufacturer by:

Jan Nijkamp, Business Development Manager  
Veenendaal, 29 June 2016



## 10.2 Appendix B: EU-Declaration of Performance - CPR 305/2011/EU

1.Unique identification code of the product:

**Flame detector – Point detector  
UV-185/5CZ, UV/IR-210/1CZ or IR3-109/1CZ**

2.Type or Serial Number or any other element allowing identification of the construction product as required under Article 11(4) of the CPR:

**See flame detector Face Plate as well as the original Packing List**

3.Intended use or uses of the construction product, in accordance with the applicable harmonized technical specification, as foreseen by the manufacturer:

**Flame detectors for use in fire detection and fire alarm systems installed in and around buildings.**

4.Name, registered trade name or registered trade mark and contact address of the manufacturer as required under Article 11(5):

**SENSE-WARE Fire and Gas Detection BV, the Netherlands; [www.sense-ware.com](http://www.sense-ware.com)**

5.Where applicable, name and contact address of the authorized representative whose mandate covers the tasks specified in Article 12(2):

**See original Packing List**

6.System or systems of assessment and verification of constancy of performance of the construction product as set out in CPR, Annex V:

**System 1**

7.In case of the declaration of performance concerning a construction product covered by a harmonized standard:

**SKG (Notified body nr.0960) performed: (i) determination of the product type on the basis of type testing; (ii) initial inspection of the manufacturing plant and of factory production control; (iii) continuous surveillance, assessment and evaluation of factory production control, under system 1 and issued certificate 0960-CPR-SKG.1388.3643.**

8.In case of the declaration of performance concerning a construction product for which a European Technical Assessment has been issued:

**Not applicable**

9.Declared performance as listed: EN54-10: 2002

	Clause	Result	Remark
<b>Reproducibility</b>	5.2	Pass	
<b>Repeatability</b>	5.3	Pass	
<b>Directional dependence</b>	5.4	Pass	
<b>Fire sensitivity UV-185/5CZ and UV/IR-210/1CZ</b>	5.5	Pass	Class 2
<b>Fire sensitivity IR3-109/1CZ</b>	5.5	Pass	Class 1
<b>Dazzling (operational)</b>	5.6	Pass	
<b>Dry heat (operational)</b>	5.7	Pass	
<b>Cold (operational)</b>	5.8	Pass	
<b>Damp heat cyclic (operational)</b>	5.9	Pass	
<b>Damp heat steady state (endurance)</b>	5.10	Pass	
<b>Sulphur dioxide (SO<sub>2</sub>) corrosion (endurance)</b>	5.11	Pass	
<b>Shock (operational)</b>	5.12	Pass	
<b>Impact (operational)</b>	5.13	Pass	
<b>Vibration, sinusoidal (operational)</b>	5.14	Pass	
<b>Vibration, sinusoidal (endurance)</b>	5.15	Pass	
<b>Variation in supply parameters (operational)</b>	5.16	Pass	
<b>Electrostatic discharge (operational)</b>	5.17	Pass	
<b>Radiated electromagnetic fields (operational)</b>	5.17	Pass	
<b>Conducted disturbances induced by electromagnetic fields (operational)</b>	5.17	Pass	
<b>Fast transient bursts (operational)</b>	5.17	Pass	
<b>Slow high energy voltage surge (operational)</b>	5.17	Pass	

10.The performance of the product identified in points 1 and 2 is in conformity with the declared performance in point 9. This declaration of performance is issued under the sole responsibility of the manufacturer identified in point 4.

Signed for and on behalf of the manufacturer by:

Jan Nijkamp, Business Development Manager  
Veenendaal, 30 July 2015



### 10.3 Appendix C: EU-Declaration of Conformity - ATEX Directive 2014/34/EU

#### Sense-WARE Fire and Gas Detection B.V.

Storkstraat 7, NL- 3905 KX Veenendaal, the Netherlands, EU

**Description:** UV, UV/IR and IR3 flame detectors

**Brand Name:** SENSE-WARE

**Model:** Flame detector 210 series



Article	Specification	Classification
UV-185/5CZ	Ultraviolet Flame Detector	ATEX cat. 3GD
UV/IR-210/1CZ	Ultraviolet/Infrared Flame Detector	ATEX cat. 3GD
IR3-109/1CZ	Triple Infrared Flame Detector	ATEX cat. 3GD



II 3G Ex nA IIC T4 Gc  
II 3D Ex tc IIIC T 71°C Dc IP65  
Ambient temperature : -25°C to +70°C

**DEKRA Certification B.V.**, Meander 1051, 6825 MJ Arnhem, the Netherlands

DEKRA 13ATEX0077X

Type certificate

The object of the declaration described above is in conformity with the relevant Union harmonisation legislation:

-EN 60079-0:2012 + A11:2013

-EN 60079-15:2010

-EN 60079-31:2014

Equipment and protective systems intended for use in potentially explosive atmospheres Directive 2014/34/EC ATEX.

This declaration of conformity is issued under the sole responsibility of the manufacturer. On behalf of the above named company, I declare that, on the date the equipment accompanied by this declaration is placed on the market, the equipment conforms with all technical and regulatory requirements of the above listed directives.

Date: 1 June 2016

Jan Nijkamp

Business Development Manager

#### Warning:

1. Never open the equipment in a situation where explosive gas or dust is present.
2. The flame detector should be installed and commissioned in accordance with the Manual.
3. The screws of the housing lid should be tightened with a torque of 2 Nm.
4. The screws of the wire terminals should be tightened with a torque of 0.4 Nm.
5. The alarm- and EOL resistor must be rated 2 W minimum each and the total power dissipation of both alarm- and EOL resistor should not exceed 2 W.
6. When cleaning the swivel mount SM21, exclusively use a damp micro fiber cloth to avoid the mount from getting static.

#### Special conditions:

1. When the temperature under rated conditions exceeds 70°C at the cable or conduit entry point, or 80°C at the branching point of the conductors, the temperature specification of the selected cable shall be in compliance with the actual measured temperature values.
2. Provisions shall be made to prevent the rated voltage from being exceeded by transient disturbances of more than 119 V.



## 10.4 Appendix D: IECEx-Declaration of Conformity - Hazardous Areas

### SENSE-WARE Fire and Gas Detection B.V.

Storkstraat 7, NL- 3905 KX Veenendaal, the Netherlands, EU

**Description:** UV, UV/IR and IR3 flame detectors

**Brand Name:** SENSE-WARE

**Model:** Flame detector 210 series

Article	Specification	Classification
UV-185/5CZ	Ultraviolet Flame Detector	Ex n, Ex t
UV/IR-210/1CZ	Ultraviolet/Infrared Flame Detector	Ex n, Ex t
IR3-109/1CZ	Triple Infrared Flame Detector	Ex n, Ex t

Ex nA IIC T4 Gc

Ex tc IIIC T 71 °C Dc IP65

Ambient temperature : -25 °C to +70 °C

**DEKRA Certification B.V.**, Meander 1051, 6825 MJ Arnhem, the Netherlands

IECEx DEK 15.0055x

Type certificate

-IEC 60079-0: 2011 + Corr. 1: 2012 + Corr. 2: 2013

-IEC 60079-15:2010

-IEC 60079-31:2013

Equipment and protective systems intended for use in potentially explosive atmospheres.

On behalf of the above named company, I declare that, on the date the equipment accompanied by this declaration is placed on the market, the equipment conforms with all technical and regulatory requirements of the above listed directives.

Date: 7 October 2015

Jan Nijkamp

Business Development Manager

### Warning:

7. Never open the equipment in a situation where explosive gas or dust is present.
8. The flame detector should be installed and commissioned in accordance with the Manual.
9. The screws of the housing lid should be tightened with a torque of 2 Nm.
10. The screws of the wire terminals should be tightened with a torque of 0.4 Nm.
11. The alarm- and EOL resistor must be rated 2 W minimum each and the total power dissipation of both alarm- and EOL resistor should not exceed 2 W.
12. When cleaning the swivel mount SM21, exclusively use a damp micro fiber cloth to avoid the mount from getting static.

### Special conditions:

1. When the temperature under rated conditions exceeds 70 °C at the cable or conduit entry point, or 80 °C at the branching point of the conductors, the temperature specification of the selected cable shall be in compliance with the actual measured temperature values.
2. Provisions shall be made to prevent the rated voltage from being exceeded by transient disturbances of more than 119 V.



## 10.5 Appendix E: North American approvals – cFMus class 3611 & FM class 3260

All drawings and other details are listed in the “Document List 210-series flame detector”.

FM approvals for the:

UV-185/5CZ UV Flame Detector  
UV/IR-210/1CZ UV/IR Flame Detector  
IR3-109/1CZ IR3 Flame Detector



Nonincendive per FM class 3611: Class I, II, III, Div. 2, Groups A, B, C, D, F, G  
Nonincendive per C22.2 No. 213: Class I, Div. 2, Groups A, B, C, D  
Dust-tight per C22.2 No. 25: Class II, III, Div. 2, Groups F, G

Ambient temperature : -25°C to +70°C  
Temperature Code: T4 at Ta < +70°C  
Ingress Protection: IP65

### Warnings:

1. The power supply of the flame detector must comply with NEC class 2, as described by the National Electrical Code (ANSI / NFPA 70).
2. Cable used with the flame detector must be PLTC or ITC type as described by the National Electrical Code (ANSI / NFPA 70); twisted shielded pairs.
3. When cleaning the swivel mount SM21, exclusively use a damp micro fiber cloth to avoid the mount from getting static.
4. The screws of the housing lid should be tightened with a torque of 2 Nm.
5. The screws of the wire terminals should be tightened with a torque of 0.4 Nm.
6. The alarm- and EOL resistor must be rated 2 W minimum each and the total power dissipation of both alarm- and EOL resistor should not exceed 2 W.
7. Substitution of components may impair suitability for division 2.
8. Do not open when energized.
9. Explosion hazard. Do not remove or replace while circuit is powered or when a flammable or combustible atmosphere is present.
10. Explosion hazard. Do not disconnect equipment when a flammable or combustible atmosphere is present.
11. Explosion hazard. Do not disconnect while circuit is powered unless the area is known to be non-hazardous.

-For language translation assistance, contact your local representative, or email: [info@sense-ware.com](mailto:info@sense-ware.com)

-Pour la langue de traduction aide, contactez votre représentant local ou envoyez, un e-mail: [info@sense-ware.com](mailto:info@sense-ware.com)

### Avertissement:

Risque d'explosion. Ne pas débrancher tant que le circuit est sous tension, à moins qu'il ne s'agisse d'un emplacement non dangereux.



Performance per FM class 3260:2000

Operating temperature : -40 °C to +70 °C

Response characteristics

Fuel	UV-185/5CZ	UV/IR-210/1CZ	IR3-109/1CZ	time
n-Heptane 30 x 30 cm (1 sqft)	23 m (75 ft)	23 m (75 ft)	35 m (115 ft)	within 10 sec.
Alcohol (Ethanol) 50 x 50 cm (20 inch by 20 inch)	18.3 m (60 ft)	18.3 m (60 ft)	30 m (98 ft)	within 10 sec.
Methane plume 35 cm (1.1 ft) 1 Bar (15 psi) 5 cm (2") diam.	8 m (26 ft)	2 m (6.5 ft)	4 m (13 ft)	within 10 sec.
Propane plume 40 cm (1.3 ft) 0.5 Bar (7 psi) 1 cm (0.4") diam.	8 m (26 ft)	2 m (6.5 ft)	4 m (13 ft)	within 10 sec.

Unwanted alarm immunity

Source	UV-185/5CZ	UV/IR-210/1CZ	IR3-109/1CZ
Sunlight, direct, reflected, unmodulated	no alarm	no alarm	no alarm
Sunlight, direct, reflected, modulated	no alarm	no alarm	no alarm
Shielded Quartz Halogen lamp 500 W unmodulated @ 2 m (7 ft)	no alarm	no alarm	no alarm
Shielded Quartz Halogen lamp 500 W modulated @ 2 m (7 ft)	no alarm	no alarm	no alarm
Shielded Fluorescent lamp 20 W unmodulated @ 2 m (7 ft)	no alarm	no alarm	no alarm
Shielded Fluorescent lamp 20 W modulated @ 2 m (7 ft)	no alarm	no alarm	no alarm
Electric Heater with fan 3000 W unmodulated @ 2 m (7 ft)	no alarm	no alarm	no alarm
Electric Heater with fan 3000 W modulated @ 2 m (7 ft)	no alarm	no alarm	no alarm
Arc welding	alarm	no alarm 4 m (13 ft)	no alarm 3 m (10 ft)

Response characteristics in the presence of unwanted alarm sources

Source	Fire	UV-185/5CZ	UV/IR-210/1CZ	IR3-109/1CZ
Sunlight, direct, reflected, unmodulated	6" Propane @ 2 m (7 ft)	alarm within 10 s	alarm within 10 s	alarm within 10 s
Sunlight, direct, reflected, modulated	6" Propane @ 2 m (7 ft)	alarm within 10 s	alarm within 10 s	alarm within 10 s
Shielded Quartz Halogen lamp 500 W unmodulated @ 2 m (7 ft)	n-Heptane 1 sqft @ 10 m (33 ft)	alarm within 10 s	alarm within 10 s	alarm within 10 s
Shielded Quartz Halogen lamp 500 W modulated @ 2 m (7 ft)	n-Heptane 1 sqft @ 10 m (33 ft)	alarm within 10 s	alarm within 10 s	alarm within 10 s
Shielded Fluorescent lamp 20 W unmodulated @ 2 m (7 ft)	n-Heptane 1 sqft @ 10 m (33 ft)	alarm within 10 s	alarm within 10 s	alarm within 10 s
Shielded Fluorescent lamp 20 W modulated @ 2 m (7 ft)	n-Heptane 1 sqft @ 10 m (33 ft)	alarm within 10 s	alarm within 10 s	alarm within 10 s
Electric Heater with fan 3000 W unmodulated @ 2 m (7 ft)	n-Heptane 1 sqft @ 10 m (33 ft)	alarm within 10 s	alarm within 10 s	alarm within 10 s
Electric Heater with fan 3000 W modulated @ 2 m (7 ft)	n-Heptane 1 sqft @ 10 m (33 ft)	alarm within 10 s	alarm within 10 s	alarm within 10 s
Arc welding @ 4 m (13 ft)	n-Heptane 1 sqft @ 10 m (33 ft)	alarm within 10 s	alarm within 10 s	alarm within 10 s

Field of view

Fuel		UV-185/5CZ	UV/IR-210/1CZ	IR3-109/1CZ
n-Heptane	horizontal and vertical: 90°	at least 70% at +45° or -45°	at least 70% at +45° or -45°	at least 50% at +45° or -45°
Alcohol (Ethanol)	horizontal and vertical: 90°	at least 70% at +45° or -45°	at least 70% at +45° or -45°	at least 50% at +45° or -45°
Methane	horizontal and vertical: 90°	at least 70% at +45° or -45°	at least 70% at +45° or -45°	at least 70% at +45° or -45°
Propane	horizontal and vertical: 90°	at least 70% at +45° or -45°	at least 70% at +45° or -45°	at least 70% at +45° or -45°

Field of view: <90°, 50% @ 45°

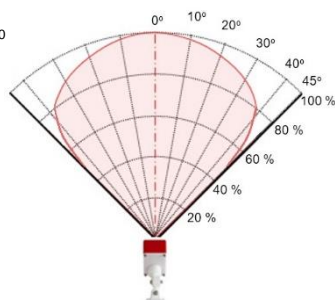

Field of view: <90°, 70% @ 45°

