

Pressure regulator U23



Pressure regulator U23
for non flammable gases (form A)



Pressure regulator U23
for oxygen (form B)

Product features

- Diaphragm pressure regulator
- For non-corrosive industrial gases
- Single-stage with high control accuracy
- Central filter in the pressure regulator
- Safety pressure gauge acc. to DIN ISO 5171
- Pressure regulator with integrated relief valve
- Pressure regulator for oxygen with filter in inlet fitting
- Accessories like wall brackets and in-/outlet fittings are also available

Technical data

Type	single-stage
Flow rate Q	max. 500 m ³ /h
Inlet pressure P₁	max. 40 bar
Outlet pressure P₂	max. 2,5 or 15 bar
Materials	
Body:	brass
Bonnet:	Alu (powder coated)
Valve seat:	PTFE
Diaphragm:	NBR
In- and outlets	
In- / outlet:	G 1/2" female
Pressure gauge ports:	G 1/4" female
Outlet relief valve:	G 3/8" male
Temperature range	-30°C to +60°C
Leak rate	<10 ⁻³ mbar l/s He
Weight	ca. 6,5 kg

Performance factors and outlet pressures to find the flow rates of the pressure regulators U23

max. outlet pressure P ₂ [bar] at 40 bar inlet pressure		1,5	2,5	15
Performance factor	L ₅ (5% pressure drop)	6	6	7
	L ₁₀ (10% pressure drop)	7,5	7,5	8,5
	L _{max}	9	9	10
Outlet pressure variations [%] relating to inlet pressure variation		1,5	1,5	2

Pressure regulator U23

spectro tec

Dimensions and connections of the pressure regulator U23 with wall bracket 723.16762 (as accessory available)

Form A (front and side view)

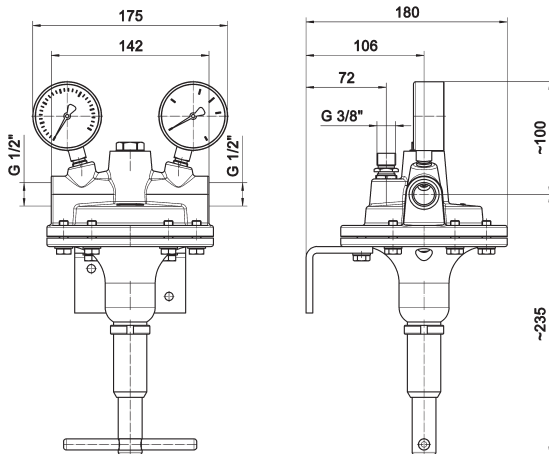

Form A (for cutting machines)

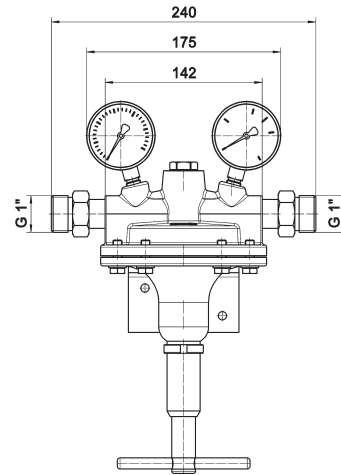

Form B (front and side view)

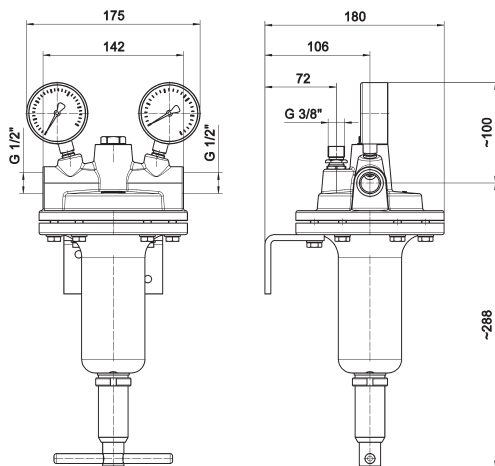

Ordering information: Pressure regulator U23

In- and outlet fittings:
see data sheet "Fittings"

U23 - 2,5 - NFG

Outlet pressure P_2

1,5	max. 1,5 bar	(Form A / acetylene)
2,5	max. 2,5 bar	(Form A)
15	max. 15 bar	(Form B)

Type of gas

NFG	non flammable gases
FG	flammable gases
O2	oxygen

For cutting machines: Art.-No. 71708107

In- / outlet: G 1" male (bull nose)

$P_2 = 2,5$ bar