

# Compact laboratory tapping points EM15 / EE15

spectro lab



with control / shut-off valve



without valve (long)



without valve



blind without regulator

## Specifications

- The special laboratory tapping points incorporate the functions shut-off, pressure regulation and pressure indication in one compact, ergonomic unit.
- EM15: for non-corrosive gases up to quality 6.0
- EE15: for corrosive gases and gas mixtures with corrosive components up to quality 6.0
- The pressure regulator is diaphragm sensed for outlet pressures up to 10 bar and piston sensed for higher outlet pressure values.
- The acetone resistant pressure gauge is safely integrated into the adjusting hand wheel to create an extremely compact device.
- Integrated shut-off valve in the rear-wall connector allows the preparation of the tapping point without pressure regulator.
- Quick and easy mounting or disassembly of the regulating unit with filled gas piping.
- Diaphragm shut-off valve with position indicator
- Optional flow control / shut-off valve in the outlet
- All gas-wetted components have undergone the special SPECTROCLEAN® cleaning process and have been thoroughly baked out.
- For ECD-applications the devices can be treated in an extended cleaning process.
- All equipment has been 100%-helium-leak-tested using a mass-spectrometer.
- All components are plastic-covered resistant to acid and alkaline solutions.
- Acetylene version optional with flashback arrester.

## Technical data

### Materials

Body	M15:	brass
	E15:	SS 1.4404 (316L)
Diaphragms:		Hastelloy C276
other gas wetted surfaces:		brass or SS 1.4404 (316L)
Valve cone:		SS 1.4404 (316L)
Valve seat:		PTFE
Cover:		Polypropylene GB30

### Leak rate

(to atmosphere):  $10^{-8}$  mbar l/s He

### Filter

150  $\mu$ m

### Pressure ranges

Inlet $P_1$ ( $P_2$ up to 10 bar):	max. 40 bar
( $P_2 > 10$ bar):	max. 100 bar
max. outlet pressure $P_2$ :	1,0 / 1,5 / 2,5 / 5 / 10 / 16 / 25 / 65 bar

$P_2$  up to 10 bar: The pressure setting will be done at 10 bar inlet pressure. The limitation of the outlet pressure setting is approx.  $P_2 + 5\%$ .

$P_2 > 10$  bar: The inlet pressure for the pressure setting will be done according to the customer's / user's specification.

### Flow rates

see flow curves

### with valve in the outlet

Connection to rear-wall connector G 3/8" RH

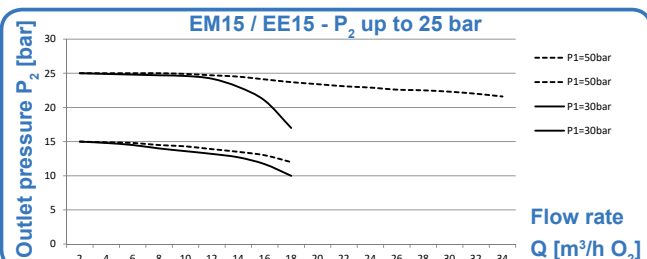
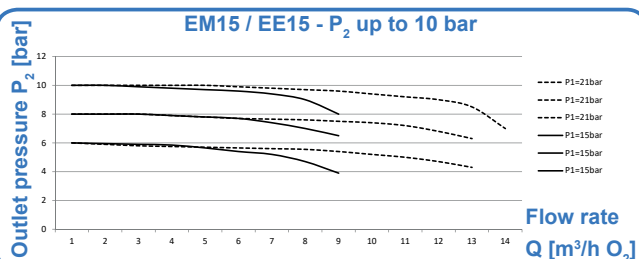
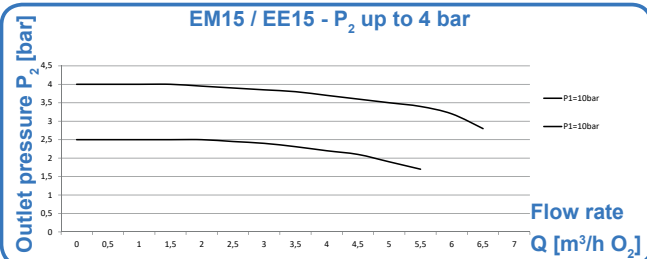
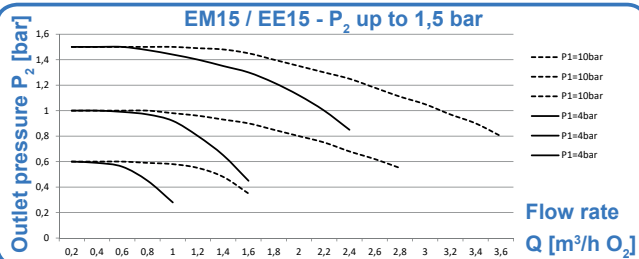

# EM15 / EE15 Ceiling-mounted Type DC

spectro lab



Ceiling-mounted tapping point  
with flow control / shut-off valve

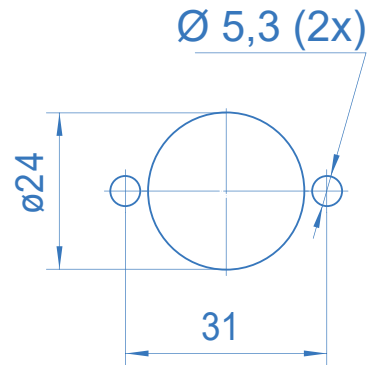

Bore template for installation

### Specifications

- The ceiling-mounted tapping point is used for installations at the ceiling.
- The ceiling-mounted version consists of a rear-wall connector made of brass or stainless steel respectively with an 1/4"-NPT female inlet, plastic covers, washer, a round faceplate and assembly accessories.

### Technical data

#### Materials

Rear-wall connector	Brass or SS
$P_1$ up to 40 bar	Brass or SS
$P_1 > 40$ bar	SS 1.4404 (316L)
Covers:	Polypropylene GB30
Washer:	Polypropylene GB30

<b>Connections</b>	inlet:	1/4"-NPT female
	outlet:	1/4"-NPT female

<b>Weight</b>	ca. 1.2 kg
---------------	------------

### Ceiling type with valve in the outlet

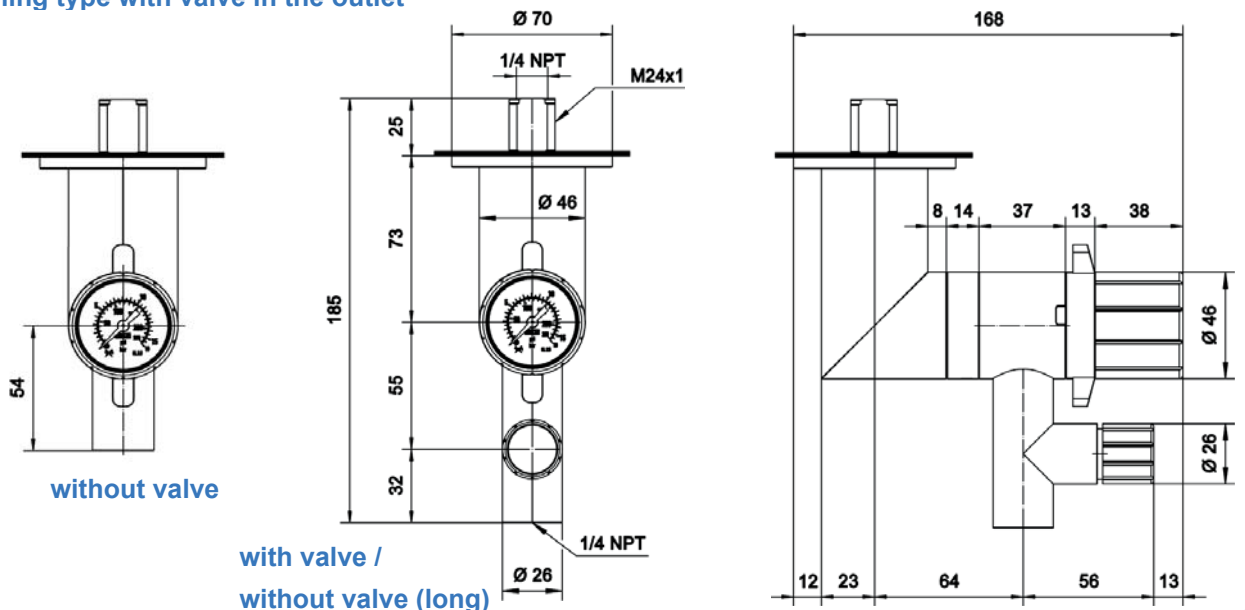

# EM15 / EE15 Rear-wall connectors

spectron lab

L7



L30

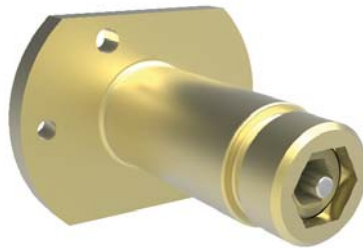

NPT

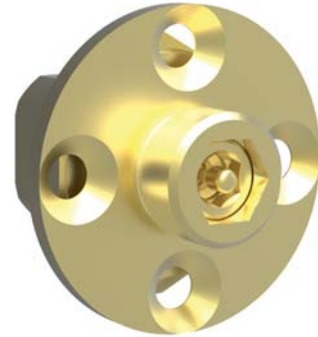

Rear-wall connectors (for surface-mounting AW and AE)  
with integrated shut-off valve

## Bore template and dimensions

1/4"-NPT female / 7 mm wall thickness (rear installation)

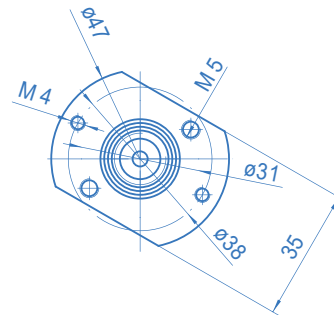
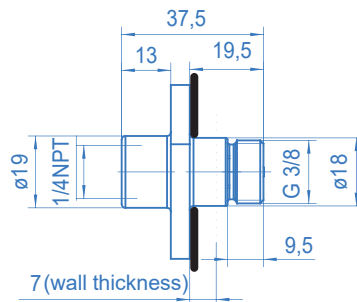

1/4"-NPT female / 30 mm wall thickness (rear installation)

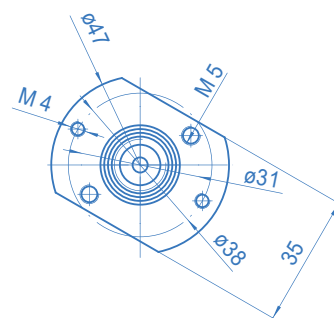
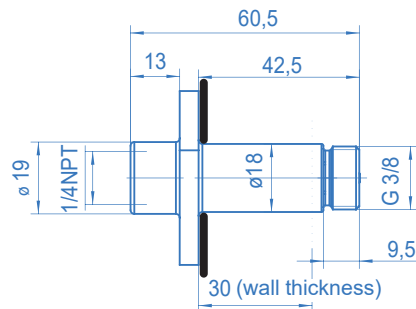

1/4"-NPT female + M24x1 male (front installation)

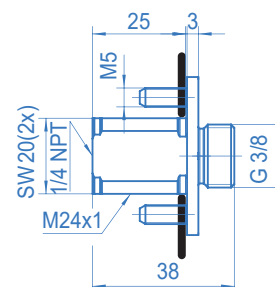
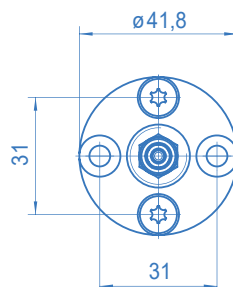
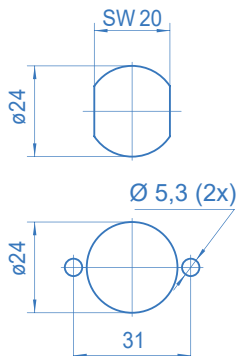

# EM15 / EE15 Ordering information

spectro lab

## Ordering information: Tapping points EM15 / EE15 series

**EM 15 - AW - 10 - 0 - V - Ar/H2**

### Material

<b>M</b>	Brass
<b>E</b>	Stainless steel

### Type

<b>AW</b>	Surface-mounted
<b>AE</b>	Surface-mounted angle version
<b>EP</b>	Panel-mounted
<b>EF</b>	Panel-mounted front
<b>DC</b>	Ceiling-mounted
<b>SC</b>	Column-mounted
<b>ES</b>	Wall-mounted
<b>GG</b>	Basic regulator w/o rear-wall conn. (G 3/8" RH)

### Pressure range

<b>1,0</b>	max. outlet pressure 1,0 bar
<b>1,5</b>	max. outlet pressure 1,5 bar
<b>2,5</b>	max. outlet pressure 2,5 bar
<b>5</b>	max. outlet pressure 5 bar
<b>10</b>	max. outlet pressure 10 bar
<b>16</b>	max. outlet pressure 16 bar (piston version up to $P_{1,max.} = 100$ bar)
<b>25</b>	max. outlet pressure 25 bar (piston version up to $P_{1,max.} = 100$ bar)
<b>65</b>	max. outlet pressure 65 bar (piston version up to $P_{1,max.} = 100$ bar)
<b>0</b>	Rear-wall connector incl. shut-off valve without pressure regulator

### Gas type

Please specify with order

### Outlet

<b>0</b>	1/4"-NPT female
<b>CM3/6/...</b>	Compression ring brass [DN]
<b>CE3/6/...</b>	Compression ring SS [DN]
<b>SM</b>	Hose connector brass
<b>SE</b>	Hose connector SS
<b>CSM(E)</b>	Compr. ring+hose connector
<b>FS</b>	Flashback arrestor

<b>L</b>	1/4"-NPT female ( <b>long</b> )
<b>LCM3/6/...</b>	Compression ring brass [DN]
<b>LCE3/6/...</b>	Compression ring SS [DN]
<b>LSM</b>	Hose connector brass
<b>LSE</b>	Hose connector SS
<b>LCSM(E)</b>	Compr. ring+hose connector

<b>V</b>	Valve (1/4"-NPT female)
<b>VCM(E)6</b>	Valve with compression ring
<b>VSM(E)</b>	Valve with hose connector
<b>VCSM(E)</b>	Valve + compression ring and hose connector
<b>B</b>	Blind w/o pressure regulator

### Inlet

<b>0</b>	<b>EP/EF:</b> 1/4"-NPT female
<b>0</b>	<b>DC/ES:</b> 1/4"-NPT female
<b>L7</b>	<b>AW/AE:</b> 1/4"-NPT f / 7 mm
<b>L30</b>	<b>AW/AE:</b> 1/4"-NPT f / 30 mm
<b>NPT</b>	<b>AW/AE:</b> 1/4"-NPT female + M24x1 male
<b>CM6/8/...</b>	Compression ring brass [DN]
<b>CE6/8/...</b>	Compression ring SS [DN]
<b>CM(E)6w</b>	angle compression ring [DN]
<b>RS</b>	SS-tube stub 6x1 mm
<b>X</b>	without rear-wall connection



## Ordering information: Valve / Wall outlet

**VM 15 - AW - 0 - EV - 0 - Ar/H2**

### Model

<b>V</b>	Valve
<b>A</b>	Wall outlet

### Material

<b>M</b>	brass
<b>E</b>	Stainless steel

### Type

see above

<b>GG</b>	Basic unit w/o rear-wall conn. (G 3/8" RH)
-----------	--

### Gas type (see above)

### Outlet (see above)

### Version

<b>DV</b>	Globe version
<b>EV</b>	Angle version

### Inlet (see above)

