

Compact laboratory tapping points EM15 / EE15

spectro lab



with control / shut-off valve



without valve (long)



without valve



blind without regulator

Specifications

- The special laboratory tapping points incorporate the functions shut-off, pressure regulation and pressure indication in one compact, ergonomic unit.
- EM15: for non-corrosive gases up to quality 6.0
- EE15: for corrosive gases and gas mixtures with corrosive components up to quality 6.0
- The pressure regulator is diaphragm sensed for outlet pressures up to 10 bar and piston sensed for higher outlet pressure values.
- The acetone resistant pressure gauge is safely integrated into the adjusting hand wheel to create an extremely compact device.
- Integrated shut-off valve in the rear-wall connector allows the preparation of the tapping point without pressure regulator.
- Quick and easy mounting or disassembly of the regulating unit with filled gas piping.
- Diaphragm shut-off valve with position indicator
- Optional flow control / shut-off valve in the outlet
- All gas-wetted components have undergone the special SPECTROCLEAN® cleaning process and have been thoroughly baked out.
- For ECD-applications the devices can be treated in an extended cleaning process.
- All equipment has been 100%-helium-leak-tested using a mass-spectrometer.
- All components are plastic-covered resistant to acid and alkaline solutions.
- Acetylene version optional with flashback arrester.

Technical data

Materials

Body	M15:	brass
	E15:	SS 1.4404 (316L)
Diaphragms:		Hastelloy C276
other gas wetted surfaces:		brass or SS 1.4404 (316L)
Valve cone:		SS 1.4404 (316L)
Valve seat:		PTFE
Cover:		Polypropylene GB30

Leak rate

(to atmosphere): 10^{-8} mbar l/s He

Filter

150 μ m

Pressure ranges

Inlet P_1 (P_2 up to 10 bar):	max. 40 bar
($P_2 > 10$ bar):	max. 100 bar
max. outlet pressure P_2 :	1,0 / 1,5 / 2,5 / 5 / 10 / 16 / 25 / 65 bar

P_2 up to 10 bar: The pressure setting will be done at 10 bar inlet pressure. The limitation of the outlet pressure setting is approx. $P_2 + 5\%$.

$P_2 > 10$ bar: The inlet pressure for the pressure setting will be done according to the customer's / user's specification.

Flow rates

see flow curves

with valve in the outlet

Connection to rear-wall connector G 3/8" RH

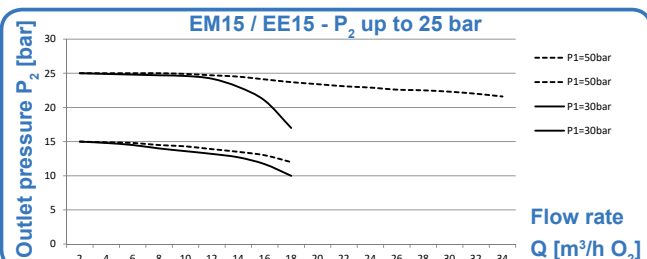
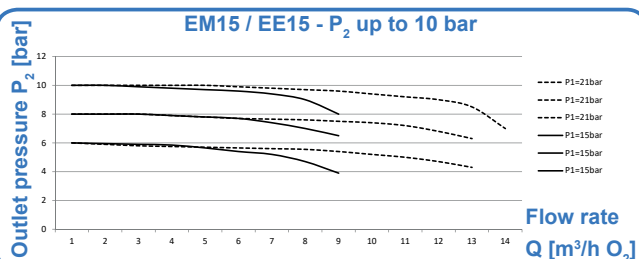
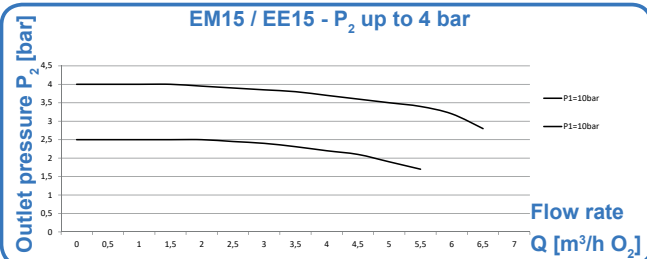
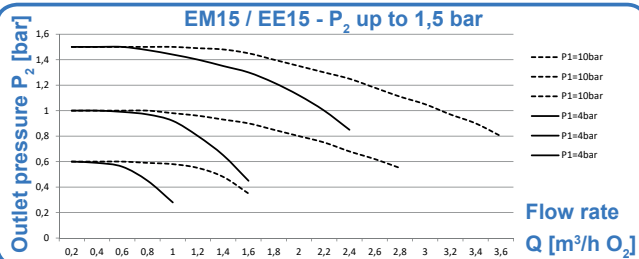

EM15 / EE15 Wall-mounted Type ES

spectro lab



Wall-mounted tapping point
with flow control / shut-off valve

Ø 8 (2x) for plug Ø 8 mm

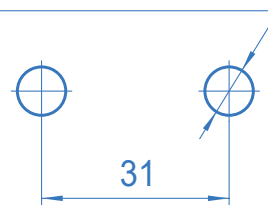

Bore template for installation

Specifications

- The wall-mounted tapping point is used for installations with surface-mounted pipe work.
- The wall-mounted version consists of a metal wall connector to connect both the gas line and the tapping point, a round faceplate and plastic covers.

Technical data

Materials

Wall connector: brass or SS 1.4404 (316L)
Covers: Polypropylene GB30

Connections inlet: 1/4"-NPT female
outlet: 1/4"-NPT female

Weight ca. 1.0 kg

Wall-mounted type ES

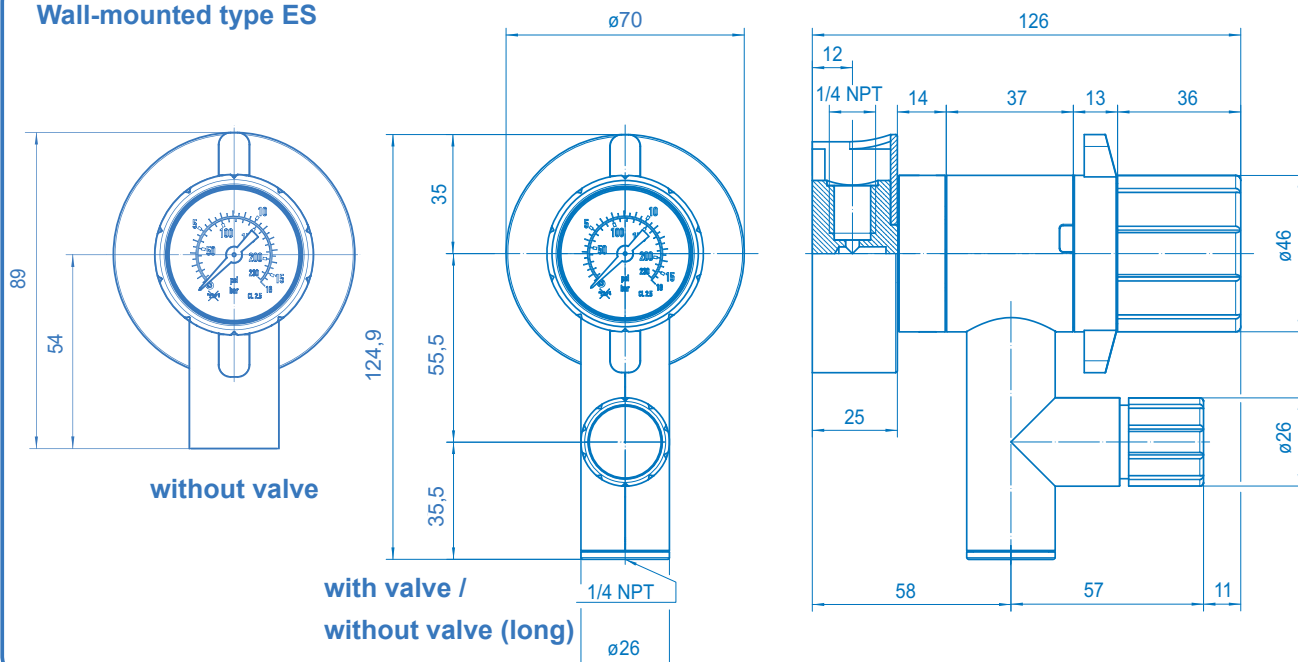

EM15 / EE15 Rear-wall connectors

L7



L30

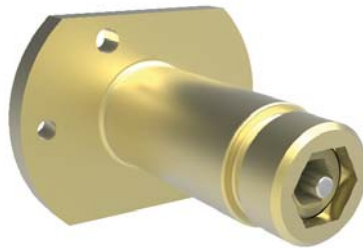

NPT

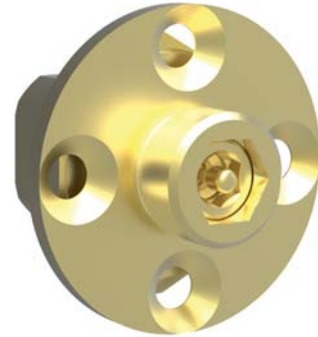

Rear-wall connectors (for surface-mounting AW and AE)
with integrated shut-off valve

Bore template and dimensions

1/4"-NPT female / 7 mm wall thickness (rear installation)

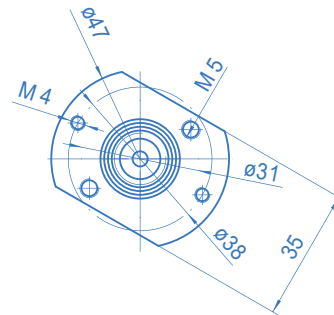
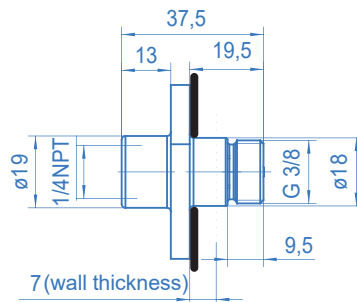

1/4"-NPT female / 30 mm wall thickness (rear installation)

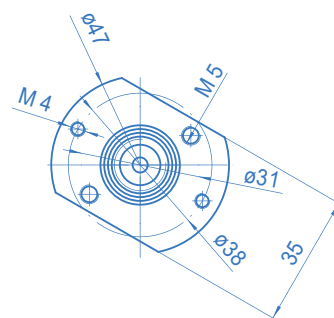
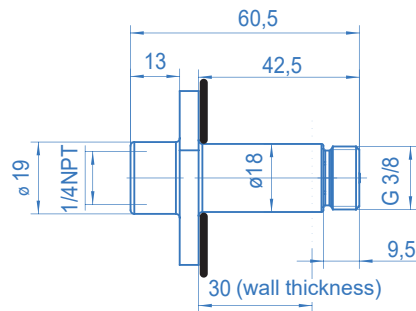

1/4"-NPT female + M24x1 male (front installation)

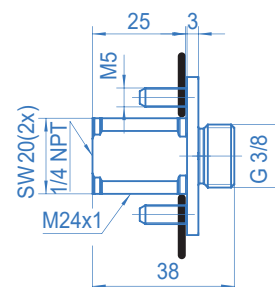
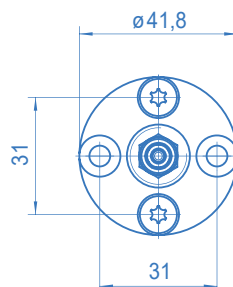
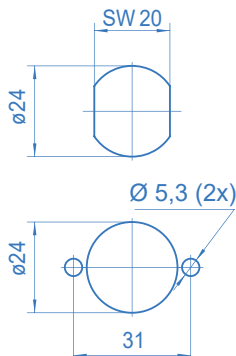

EM15 / EE15 Ordering information

spectro lab

Ordering information: Tapping points EM15 / EE15 series

EM 15 - AW - 10 - 0 - V - Ar/H2

Material

M	Brass
E	Stainless steel

Type

AW	Surface-mounted
AE	Surface-mounted angle version
EP	Panel-mounted
EF	Panel-mounted front
DC	Ceiling-mounted
SC	Column-mounted
ES	Wall-mounted
GG	Basic regulator w/o rear-wall conn. (G 3/8" RH)

Pressure range

1,0	max. outlet pressure 1,0 bar
1,5	max. outlet pressure 1,5 bar
2,5	max. outlet pressure 2,5 bar
5	max. outlet pressure 5 bar
10	max. outlet pressure 10 bar
16	max. outlet pressure 16 bar (piston version up to $P_{1,max.} = 100$ bar)
25	max. outlet pressure 25 bar (piston version up to $P_{1,max.} = 100$ bar)
65	max. outlet pressure 65 bar (piston version up to $P_{1,max.} = 100$ bar)
0	Rear-wall connector incl. shut-off valve without pressure regulator

Gas type

Please specify with order

Outlet

0	1/4"-NPT female
CM3/6/...	Compression ring brass [DN]
CE3/6/...	Compression ring SS [DN]
SM	Hose connector brass
SE	Hose connector SS
CSM(E)	Compr. ring+hose connector
FS	Flashback arrestor

L	1/4"-NPT female (long)
LCM3/6/...	Compression ring brass [DN]
LCE3/6/...	Compression ring SS [DN]
LSM	Hose connector brass
LSE	Hose connector SS
LCSM(E)	Compr. ring+hose connector

V	Valve (1/4"-NPT female)
VCM(E)6	Valve with compression ring
VSM(E)	Valve with hose connector
VCSM(E)	Valve + compression ring and hose connector
B	Blind w/o pressure regulator

Inlet

0	EP/EF: 1/4"-NPT female
0	DC/ES: 1/4"-NPT female
L7	AW/AE: 1/4"-NPT f / 7 mm
L30	AW/AE: 1/4"-NPT f / 30 mm
NPT	AW/AE: 1/4"-NPT female + M24x1 male
CM6/8/...	Compression ring brass [DN]
CE6/8/...	Compression ring SS [DN]
CM(E)6w	angle compression ring [DN]
RS	SS-tube stub 6x1 mm
X	without rear-wall connection



Ordering information: Valve / Wall outlet

VM 15 - AW - 0 - EV - 0 - Ar/H2

Model

V	Valve
A	Wall outlet

Material

M	brass
E	Stainless steel

Type

see above

GG	Basic unit w/o rear-wall conn. (G 3/8" RH)
-----------	--

Gas type (see above)

Outlet (see above)

Version

DV	Globe version
EV	Angle version

Inlet (see above)

