

Pneumatic pressure regulator U12 E



Pressure regulator U12 E - G 1 m

Product features

- Dome loaded diaphragm line pressure regulator
- For non corrosive industrial gases
- Remote controlled pressure regulation (e.g. process control or cutting machines)
- For flow rates up to 300 m³/h air
- Pressure control with process gas by small pressure regulator ST2000
- Single-stage with high control accuracy
- Outlet pressure reduction by special vent hole in the diaphragm assembly
- Central filter in the pressure regulator
- Pressure regulator with integrated relief valve
- Wall brackets available as accessory
- Approved for use with oxygen

Attention:

For the U12 special fittings with orifice holes have to be used to ensure a correct function of the pressure regulator.

Technical data

Type	single-stage
Flow rate Q	max. 300 m ³ /h
Inlet pressure P₁	max. 40 bar*
Outlet pressure P₂	max. 4 ... 30 bar
Materials	
Body:	brass
Valve seat:	PA
Diaphragm:	NBR
Connections	
In- / outlet (body):	G 1/2" female
Pressure gauge ports (body):	G 1/4" female
Pressure gauge connection:	G 3/8" male
Outlet relief valve:	G 3/8" male
Temperature range	-20°C to +60°C
Leak rate	≤10 ⁻⁴ mbar l/s He
Weight	ca. 2,8 kg

* higher inlet pressure upon request

Performance factors for evaluation of flow rates for pressure regulator U12 E

Performance factor	L ₅ (5% pressure drop)	6
	L ₁₀ (10% pressure drop)	7,5
	L _{max}	9
Outlet pressure variations [%] relating to inlet pressure variation		2,7

The outlet pressure and accordingly the accuracy will be determined by the pilot pressure regulator ST2000 (see data sheet).

Dimensions and connections

Dimensions with **wall bracket 512.07600**
(as accessory available)

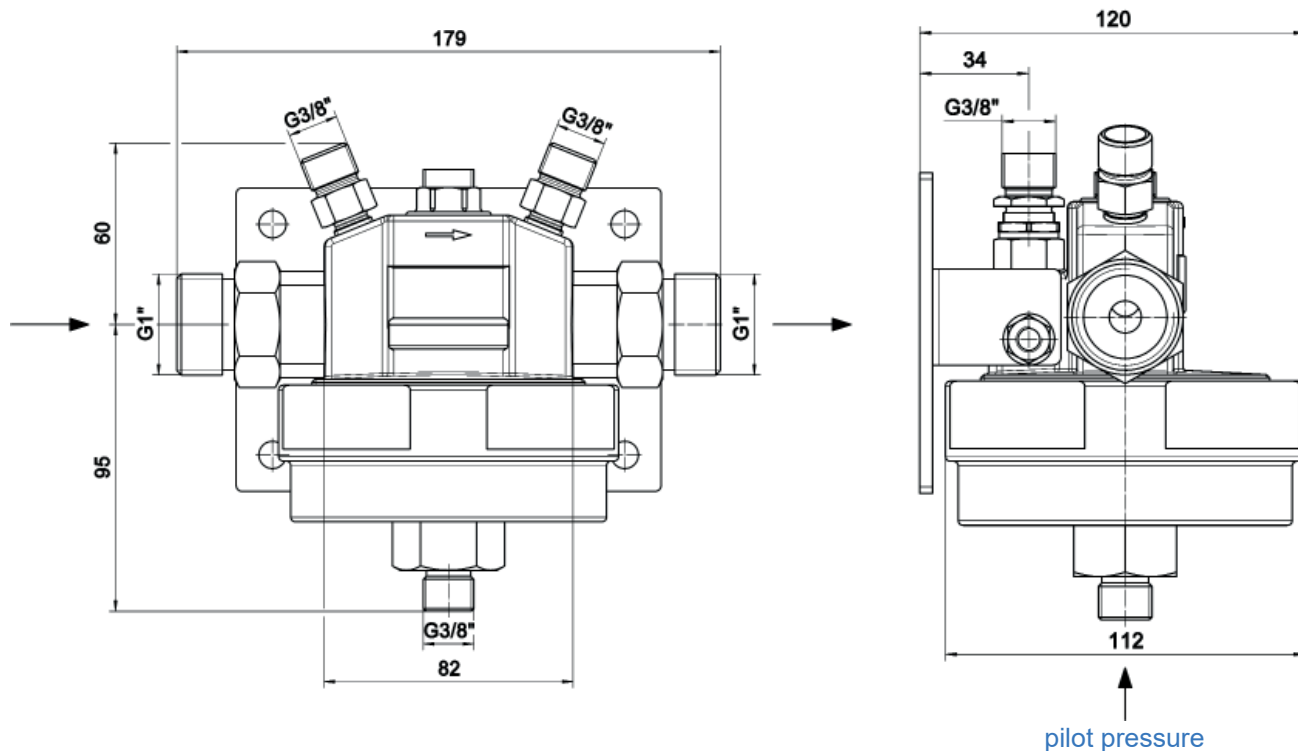

Ordering information: Pressure regulator U12 E

U12 E - G 1/2 f

In- and outlet fittings:
see data sheet "fittings"

In- / outlet	Art.-no.
G 1/2 f G 1/2" female	717.08955
G 1 m G 1" male	717.00741

Diagram for process gas controlled dome loaded pressure regulator

