

Pressure control panel BM55-2

spectro lab

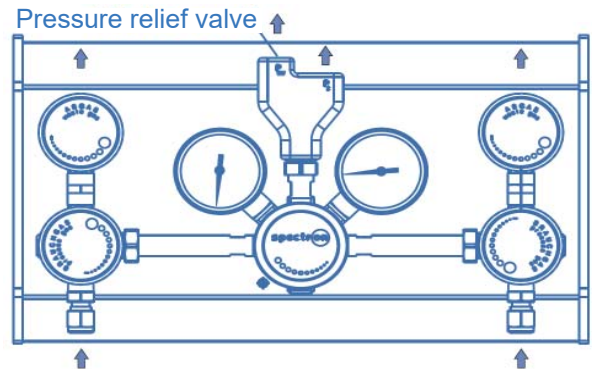

BM55-2 without valve in the outlet adapter



Product features

- Wall- and cabinet-mounting pressure control panels with manual change-over function
- For non-corrosive gases up to quality 6.0
- Modular design (to be extended to 2, 3 etc. cylinders)
- Filter at the process gas inlet valve
- Diaphragm-type shut-off valves optimised for low internal volume with On/Off position indicator
- Suitable for ECD-applications
- Diaphragm-type pressure regulator with high control accuracy up to 200 bar outlet pressure and anti-vibration device
- Outlet adapter with integrated relief valve (up to 100 bar) and optional diaphragm shut-off valve (this prevents the outlet piping from draining during disconnecting the panel)
- Laboratory-style design for easy installation
- Approved for use with oxygen
- Suitable for inlet pressure values up to 300 bar
- Compact design especially for installation into safety cabinets for gas cylinders

Technical data

Type single-stage

Inlet pressure P_1 max. 300 bar

Outlet pressure P_2 max. 10 / 20 / 50 / 100 / 200 bar

Materials

Body regulator and valves: chrome-plated brass
 Valve seat regulator: PA 11
 Valve seat valves: PVDF
 Diaphragm regulator: Hastelloy C276
 Diaphragm valves: Hastelloy C276
 Soft goods: EPDM, FKM
 Filter regulator: sintered SS 1.4404

Connections SS compression ring fitting 6x1 mm
 Inlet:
 Outlet: 1/4"-NPT female

Temperature range -20 to +60°C

Leak rate
 to atmosphere: $\leq 10^{-8}$ mbar l/s He
 via seat: $\leq 10^{-6}$ mbar l/s He

Weight 6,5 kg

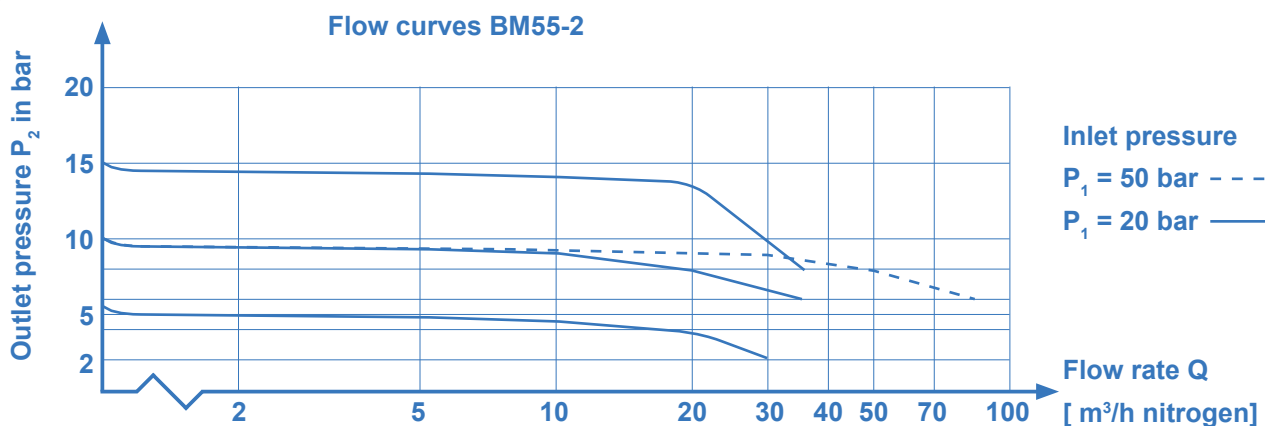

Pressure control panel BM55-2

spectro lab

Dimensions and connections

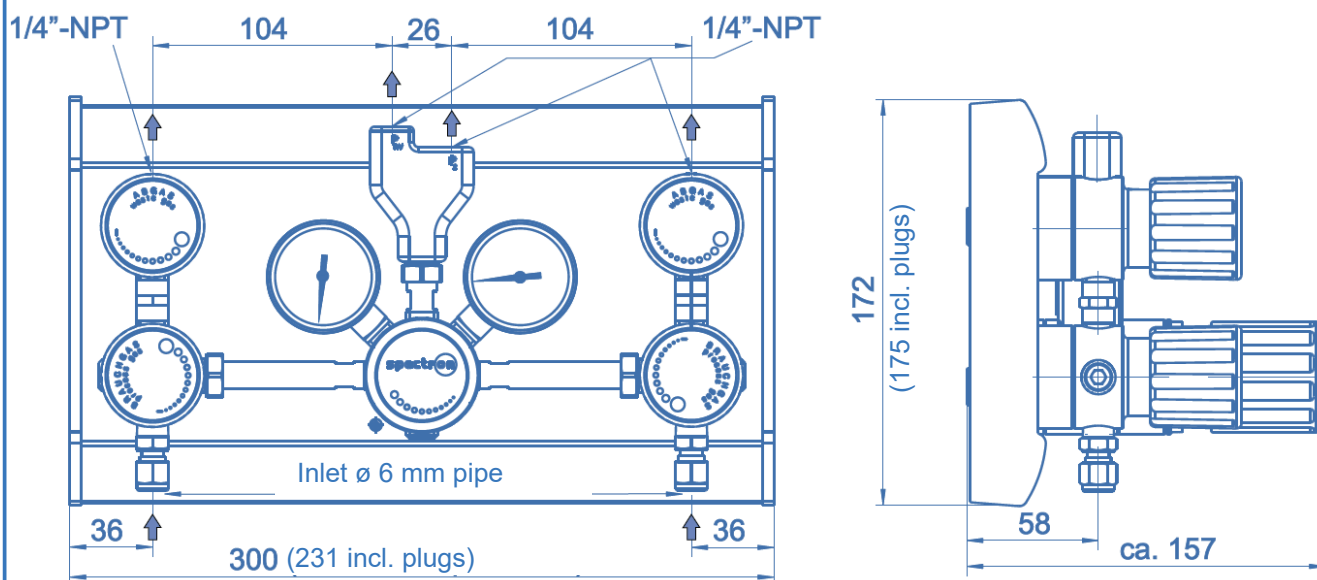

Ordering information: Pressure control panel BM55-2

BM55 - 2 - 300 - 10 - V - V - M - M - V - N2

Inlet pressure P_1

100	max. 100 bar
200	max. 200 bar
300	max. 300 bar

Outlet pressure P_2

10	max. 10 bar
20	max. 20 bar
50	max. 50 bar
100	max. 100 bar
200	max. 200 bar

Process gas inlet HPI

High press. waste gas HPV

V	valve (manual)
VP	pneumatic valve (NC)

Gas type

Please specify gas type!

Outlet adapter

0	without valve
V	valve (manual)
VP	pneumatic valve (NC)

Outlet press. indication

Inlet pressure indication

M	pressure gauge
K	contact press. gauge
PT	pressure transmitter