

Operating Manual

APOLLO[®] 50 - 1,3 bar

APOLLO[®] 100 - 1,3 bar

APOLLO[®] 150 - 1,3 bar

with capacitive filling

level indicator

Table of Contents	<u>Page</u>
1 Introduction	1
1.1 Symbols in the Manual	1
1.2 Principle	1
1.3 Delivery	1
2 Vessel	2
2.1 Main Components	2
2.2 Specifications of the Vessel	2
2.3 Specifications of the Safety Valve	2
2.4 Examination of Safety Valve	3
2.5 Combined Positive Pressure Relief and Seal-off Device	4
2.6 Siphon with Small Flange Connection Type EK	4
2.7 Transfer Hose	5
2.10 Pressure Build-up Control System	8
2.11 Pressure relief regulator (Option)	9
2.12 Spare Parts / Accessories	10
2.13 Schematic description APOLLO with C-Stic - Capacitive level indicator	11
3 Safety	12
3.1 Safety advices	12
3.2 How to handle liquid Nitrogen	12
3.3 General Safety Instructions	12
3.4 Proper Use according to the Regulations	12
3.1 Safety advices "Handling with cryogenic liquefied gases" Source: IGV Germany	13
3.2 Note Road Transportation	17
3.3 Labelling	18
4 Transportation and Assembly	19
4.1 General Transportation	19
4.2 Assembly	19
4.3 Transport valve for APOLLO® receptacle	19
5 Operation	22
5.1 Initial Commissioning	22
5.2 Assembly and Disassembly of the EK Siphon	22
5.3 Assembly of the Transfer Hose	23
5.4 Filling of the Vessel	24
5.5 Withdrawal of liquid Nitrogen	25
5.6 Pressure Build-up	26
5.7 Pressure Relief	27
5.8 Putting out of Operation	28
5.9 Operating Instructions	28
6 Maintenance / Repair	29
7 Faults	30
7.1 General Faults	30
7.2 Possible Faults	31
8 Warranty	32

Appendix: name plate
Certificate/Declaration of Conformity
List of pressure device and equipment

1 Introduction

The APOLLO® Vessel is a vacuum super insulated pressure vessel made of corrosion-resistant stainless steel. It is intended exclusively for storing nitrogen (cryogenic liquid nitrogen).

The APOLLO® Vessel acc. to Directive for Pressure Devices 2014/68/EU
Category I Module A., with CE - marking

1.1 Symbols in the Manual



This sign points out to dangerous situations resulting in possible

- injury to persons
- damage to the environment
- damage to devices



This sign refers to

- recommendations
- explanations
- supplements

1.2 Principle

The APOLLO® Vessel may only be operated according to this operating manual.

1.3 Delivery

Immediately after receipt of the vessel, the delivery has to be examined with regard to

- completeness
- damage



In case of any shipping damage, contact

- the shipping insurance
- the shipping company
- the supplier

2 Vessel

2.1 Main Components

- Coaxial arrangement of the pressure vessel in the outer vessel with neck suspension and vacuum super insulation
- Pressure build-up device arranged in the vacuum room
- Chassis
- Safety valve
- Pressure gauge
- Dismountable siphon, Type **EK®**

2.2 Specifications of the Vessel

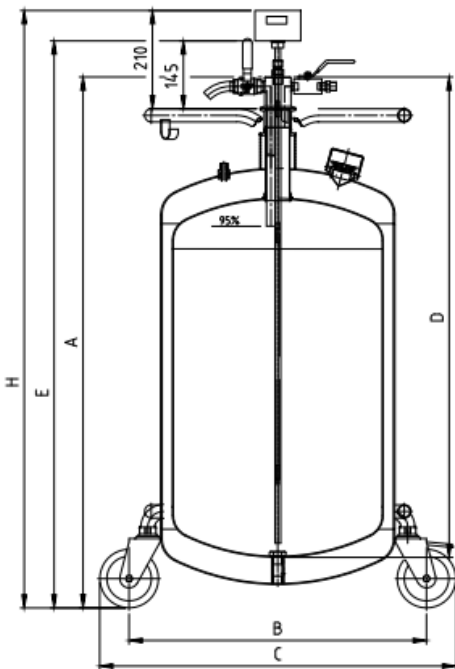

Manufacturer		Cryotherm GmbH & Co. KG		
Type		APOLLO® 50 - 1,3 bar	APOLLO® 100 -1,3 bar	APOLLO® 150 -1,3 bar
Total height to C-Stick mm	H	885	1220	1560
Total height, cm	E	820	1155	1495
Outside diameter, cm	A	765	1100	1435
Total width, cm	B	500	500	500
Immersion depth, cm	C	650	760	760
	D	585	920	1220
Neck diameter, mm		50	50	50
Weight empty, kg		44	62	79
Weight full, kg		85	145	204
Geometrical capacity, l		49,40	98,80	149,15
Static rate of evaporation, % / day		2	1,2	1
Operating pressure, bar max.		1,3	1,3	1,3

2.3 Specifications of the Safety Valve

Type	06002
Blow-off pressure	1,3 bar

2.4 Examination of Safety Valve

2.4.1 Examination at filled vessel



Caution: danger of suffocation, examination only in well ventilated rooms, rooms with monitoring of oxygen lack or outside the building

1. Examination

- EK siphon fitted, secured with clamping flange, waste gas and withdrawal ball valve closed.
- Read the blow-off pressure of the safety valve at the valve.
- Open the pressure build-up ball valve of the vessel
- Observe the pressure increase at the vessel manometer.
-



Caution: Should the safety valve not blow-off with nominal pressure or 10% above nominal pressure, close the pressure build up ball valve and open the waste gas ball valve at the EK siphon.

**Contact Cryotherm GmbH & Co. KG
under 02741/9585-0**

- Have the safety valve blow-off. The blow-off pressure may be 10% higher or lower than the nominal pressure.
- Have the safety valve blown-off several (3 times recommended). Meanwhile, observe the pressure display at the manometer.
- Close the pressure build-up ball valve.
- Relieve the pressure from the vessel by means of the waste gas ball valve.
- Document the examination internally (recommended).

2.4.2 Examination of the safety valve in dismantled condition

- The disassembly/assembly of the safety valve may only be carried out by specialized companies
- Please contact us under:

**Cryotherm GmbH & Co. KG
02741/9585-0**

2.5 Combined Positive Pressure Relief and Seal-off Device

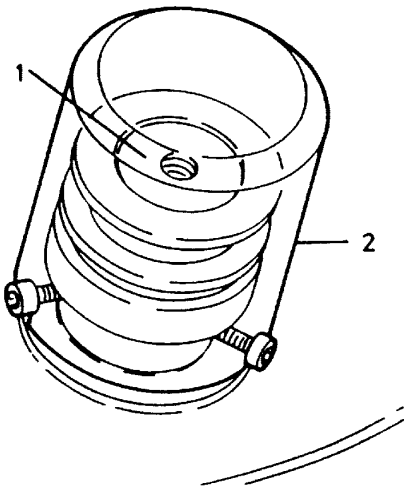

Caution! The positive pressure relief and seal-off device protects the vacuum room from overpressure. Re-evacuation may only be carried out by

- manufacturer's skilled staff



The protective cover (2) intercepts the valve insert (1), when there is overpressure existing in the vacuum room.

- Do not remove the protective cover (2).
- Protect the valve from heat as well as cooling, as brittleness results in the loss of the operating vacuum.

2.6 Siphon with Small Flange Connection Type EK

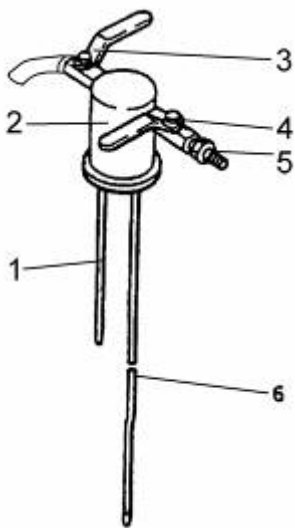

Structure of the Siphon

Item	Description
1	Waste gas/overflow line
2	Basic body with small flange connection DN 50
3	Waste gas/overflow valve G 1/2"
4	Filling/withdrawal valve G 3/8"
5	Connection screwing (double nipple ring R 3/8" - 3/4-16 UNF) for flexible transfer hose
6	Filling/withdrawal line

The siphon serves for the filling and withdrawal of liquid nitrogen.

Special designs (e.g. single / triple withdrawal) are available on request.

Ball Valve Positions:

- A - closed
- B - open

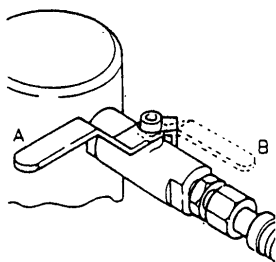

2.7 Transfer Hose

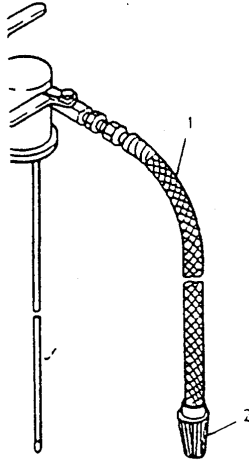

Structure of the Standard Transfer Hose

Item	Description
1	Flexible corrugated hose with a corrosion-resistant stainless steel braiding
2	Phase separator for ensuring the splash-free transfer of liquid nitrogen

**Exchange damaged hose****Protect transfer hose from**

- bending when in a cold condition
- being twisted
- being pulled
- buckling
- impacts

2.8 Level Indicator



According to enclosed separate operating manual C-Stic and short operating manual 78222573E

2.9 Determination of the Vessel Filling Level

- by determining the filling level by means of a dip rod and comparing with the filling level curve

APOLLO® 50, 100, 150 Filling Level Curve

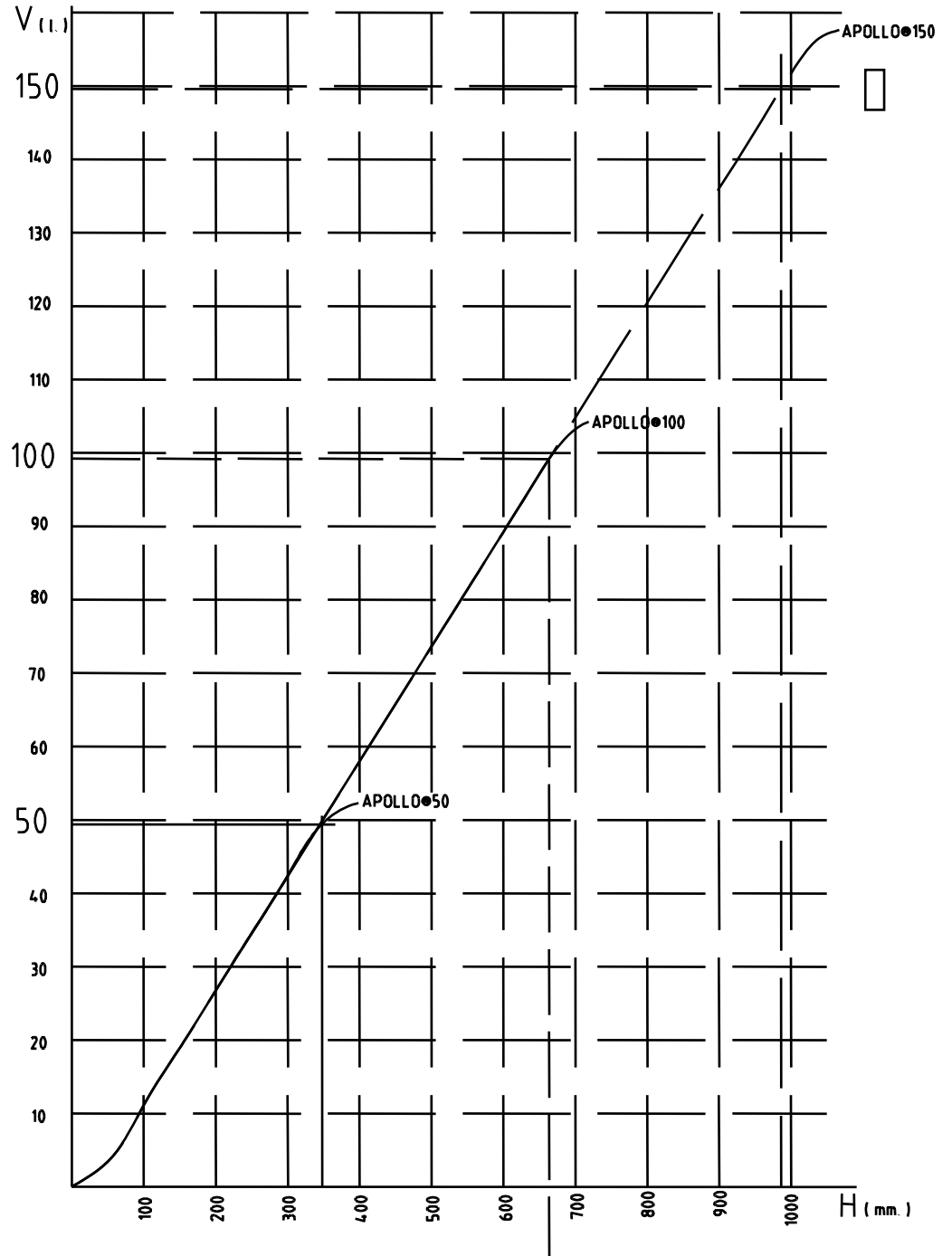

drawing 78202700

2.10 Pressure Build-up Control System

Automatic Pressure Build-up Control System (Option)

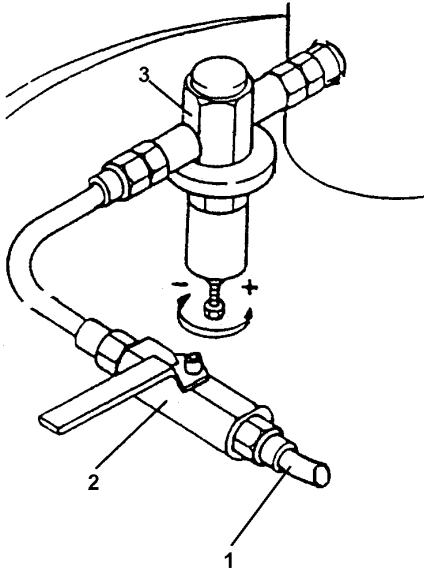

Item	Description
1	Pressure build-up line
2	Pressure build-up valve
3	Pressure build-up control valve

The automatic pressure build-up valve controls the pressure in the vessel.

It is recommended with continuous withdrawal operation.



Close the pressure build-up valve (2) prior to filling, relieving pressure or transporting.

Pressure Build-up Control

- Switch on by opening the pressure build-up valve (2), Position A.
- Switch off by closing the pressure build-up valve (2), Position B.

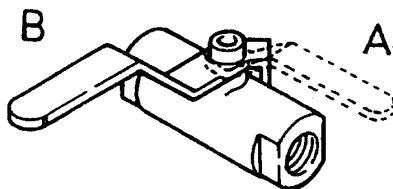

Changing the Operating Pressure

- Turning the regulating screw of the pressure build-up valve in clockwise direction causes the pressure to increase.
- Turning the regulating screw of the pressure build-up valve in counter clockwise direction causes the pressure to decrease.

Automatic Pressure Build-up Control Valve Mode of Operation:

- The pressure build-up control valve (3) will open when the pressure in the tank drops.
- The liquid nitrogen is introduced into the pressure build-up line (1) at the vessel bottom, it evaporates and is returned to the tank.
- The pressure in the tank rises to the adjusted operating pressure.
- The pressure build-up control valve (3) closes.

2.11 Pressure relief regulator (Option)

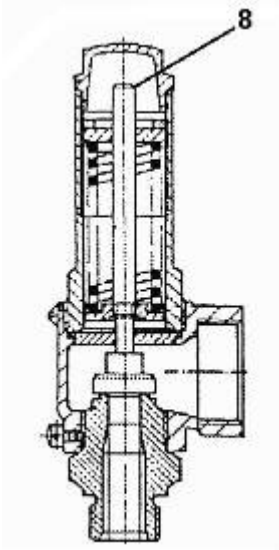

Picture: Pressure relief regulator
(Option)



Observe safety instructions!

For pressure relief close pressure build-up valve and open waste gas / overflow valve until the working pressure at Manometer 5 is achieved.

The overpressure of the vessel is limited upwards over the adjustable pressure relief regulator.

- First of all unscrew the brassed capped nut and loosen the safety lead nut.
- Adjust the desired maximum pressure (at least 0.3 bar above the set pressure of the pressure build-up control valve)
- Screw-in Regulating Screw 8 for pressure increase.
- Unscrew Regulating Screw 8 for pressure decrease.
- Tight the brassed capped nut and safety lead nut screws back again



Caution: Adjust the blowing-off pressure of the pressure relief regulator at least 0.3 bar above the blow-down pressure of pressure build-up control valve (option)

2.12 Spare Parts / Accessories

Item	Designation	Subject number	Subject number	Subject Number
		APOLLO® 50 – 1,3 bar 78202700	APOLLO® 100 – 1,3 bar 78202701	APOLLO® 150 – 1,3 bar 78202702
1	Lettering APOLLO	79406947	79406947	79406947
2	Cryotherm logo	77031445	77031445	77031445
3	Level Indicator with C-Stic	78216836	78216836	78216836
4	Ball valve 3/8"	0346570	0346570	0346570
5	Ball valve 1/2"	78211868	78211868	78211868
6	EK Siphon, complete	78202711	78202712	78202713
7	Safety valve, 1.3 bar	78212669	78212669	78212669
8	Pressure gauge 0-2.5 bar	78202716	78202716	78202716
9	Chassis	78202740	78202741	78202742
10	Castor with locking lever	78210302	78210302	78210302
11	Castor without locking lever	78210301	78210301	78210301
12	Double nipple R 3/8"-3/4-16 UNF	0793576	0793576	0793576
13	Transfer hose, 1.5 m	79229957	79229957	79229957
14	Straining ring, DN 50	0792277	0792277	0792277
15	Centering ring, DN 50 complete	0793045	0793045	0793045
	O-ring for KF 50 (separate)	0793060	0793060	0793060
16	Phase separator G 3/8" complete	79404217	79404217	79404217
17	Safety glasses	0794189	0794189	0794189
18	Transport stopper DN 50	78202417	78202417	78202417
19	Protective insulating leather gloves	0794111	0794111	0794111
20	Rating plate (adhesive film)	78220474	78220474	78220474
21	Operating instructions (adhesive film)	78222573	78222573	78222573
	Operating manual	78222574	78222574	78222574
22	GGVS / ADR - Labelling			
	Cryogenic liquid nitrogen	78400571	78400571	78400571
	GGVS adhesive label no. 2	0358193	0358193	0358193
	GGVS adhesive label ↑↑ no.11	0356199	0356199	0356199
23	Connection tube	78202718	78202718	
*	Option Instead of pos. 23 Pressure regulator	0366006	0366006	

2.13 Schematic description
 APOLLO with C-Stic - Capacitive level indicator

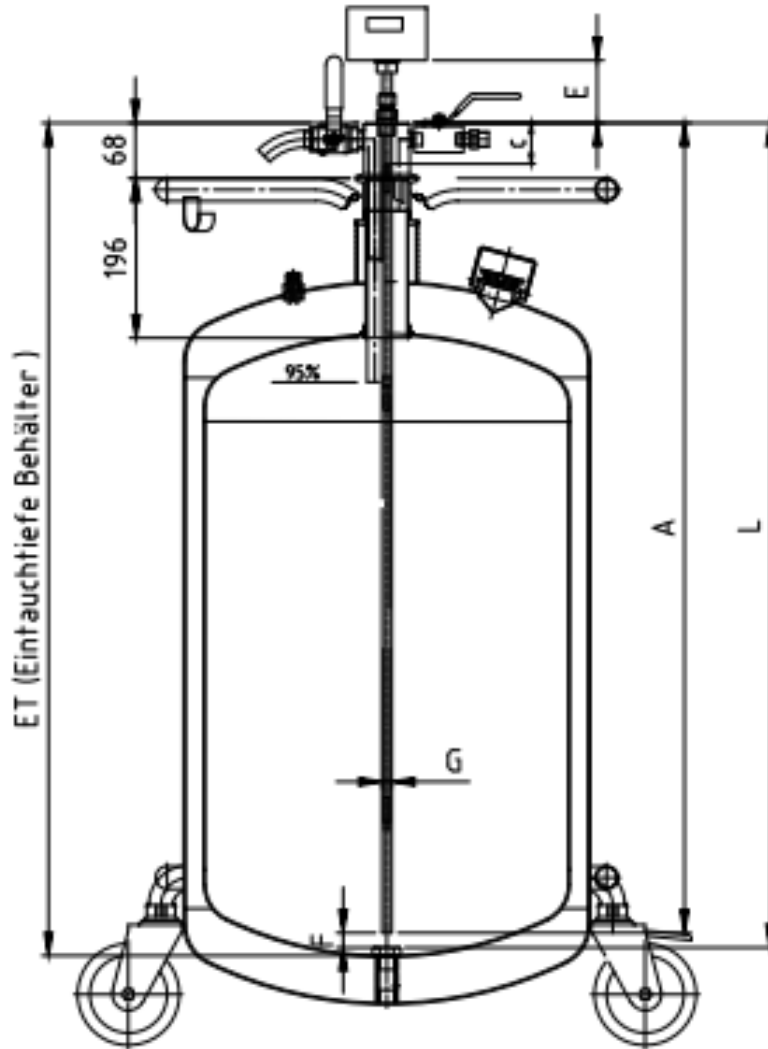

(Abmessungen in mm)										
Behälter - Typ	EK -Heber	ET	C-Stic Artikel-Nr.	L	A	C	D	G	E	F
für APOLLO 50 / Art. 78222569	78223517	585	78216837	635	621	50	1/2" BSP	φ12	77	14
für APOLLO 100 / Art. 78222565	78223525	920	78216836	970	956	50	1/2" BSP	φ12	77	14
für APOLLO 150 / Art. 78222570	78223526	1260	78216838	1310	1296	50	1/2" BSP	φ12	77	14
für APOLLO 200 / Art. 78222571	78223527	906	78216839	956	941	50	1/2" BSP	φ12	77	15
für APOLLO 350 / Art. 78222572	78223528	1380	78216840	1430	1416	50	1/2" BSP	φ12	77	14

3 Safety

3.1 Safety advices

Cryotherm GmbH & Co. KG recommend that the user request an EU – Safety data sheet for liquid nitrogen at his gas supplier

3.2 How to handle liquid Nitrogen



**Caution when handling liquid nitrogen!
Observe the following documents and procedures:**

- Safety advices „Handling with cryogenic liquefied gases ”
- Information for the road transportation
- When setting up in rooms, ensure good ventilation (TRB 610)
- Operation may only be carried out by persons instructed correspondingly (TRB 700)
- Regulation for the Prevention of Accidents „gases“ BGV B 6 (VBG61)
- Regulation for Pressure Devices

3.3 General Safety Instructions



For safe operation:

- Additional aggregates for filling/withdrawal have to be adjusted to the operating conditions of the tank.
- Test the tightness and function of the fittings at regular intervals.
- Use original spare parts.
- Employ suitable tools.
- Do not operate valves abruptly or jerkily.
- Protect lockable rooms from exceeding of the maximum operating overpressure by means of a safety valve.
- Have adjustment, maintenance and repair work done only by authorized skilled personnel.
- Do not carry out any mechanical and thermal work at the vessel (loss of vacuum).
- Do not transfuse contents with foreign gas.
- Do not overcharge the tank.
- Protect safety valves from splash water and lees.
- Wear gloves and safety glasses.
- Loosen the screwings only in unpressurized condition.

3.4 Proper Use according to the Regulations

Company Cryotherm GmbH & Co. KG does not assume any liability, if the tank is changed or adapted without approval given by the manufacturer.

Company Cryotherm GmbH & Co. KG does not assume any liability, if the tank is not properly used according to the regulations.

3.1 Safety Safety advices
“Handling with cryogenic liquefied gases”
Source: IGV Germany

Publication series: Safe handling of industrial gases



SAFETY NOTES

Safe handling of cryogenically liquefied gases

1. Preliminary remarks

These safety notes are recommendations based on practical experience for the safe handling of cryogenically liquefied gases. These safety notes complement binding safety regulations, they do not replace them.

A gas or a liquid is in an ultra-cold (or cryogenic) state, when its temperature is considerably below -50°C. The table lists some gases that are frequently handled in a cryogenic state.

Before handling cryogenically liquefied gases, it is crucial to carry out a hazard assessment of the work area and/or the equipment.

2. General information on cryogenically liquefied gases

The chemical properties of gases in a cryogenically liquefied state are in principle the same as in the “warm” state. In the ultra-cold state the physical property “cryogenic” is added. This additional property results in special characteristics that require particular attention when handling cryogenically liquefied gases, such as:

- **Contact:** direct contact with cryogenic liquids can cause severe frostbite and/or cold burns. Particularly the eyes can be damaged by accidental splashes.
- **Embrittlement:** materials (e.g. most plastics, machinery steel) become brittle at cryogenic temperatures.

The most important protective measures must be described in the operating instructions and must be observed.

3. Precautionary measures

The precautionary measures described in this paragraph apply to all cryogenically liquefied gases.

They must be applied in conjunction with the precautionary measures described in the Safety Data Sheets for Gases and other applicable security notes, as for example in the security notes regarding **oxygen deficiency**, **oxygen enrichment**, etc



3.1 Personal protective equipment

If worn continually, personal protective equipment protects from contact with cryogenic gases, liquids or system parts so that any harm to the user’s health is virtually impossible.

Clothing should be clean, dry and made of natural fibres. Clothing should be loose-fitting so that it can be taken off quickly and easily when it has come into contact with the cryogenic gas or the liquid. Arms and legs should be covered entirely. There should be no open pockets, turned-up trouser legs or rolled-up sleeves.

Physical properties of some cryogenic gases

Gas	oxygen	nitrogen	argon	hydrogen	helium	LNG	carbon dioxide
Chem. symbol	O ₂	N ₂	Ar	H ₂	He	CH ₄	CO ₂
Boiling temperature at 1013 mbar [°C]	-183	-196	-186	-253	-269	-161	-78.5 *)
density of the liquid at 1013 mbar [kg/l]	1.142	0.808	1.4	0.071	0.125	0.42	1.178 **)
Density of the gas at 15°C, 1013 mbar [kg/m ³]	1.34	1.17	1.67	0.084	0.167	0.72	1.85
Relative density compared to air at 15°C, 1013 mbar	1.06	0.95	1.36	0.0695	0.136	0.55	1.5
Volume of gas [l] derived from 1 l of liquid	853	691	839	845	749	587	832

*) Sublimation temperature

**) at 5.18 bar



When handling cold components and when the user has to be prepared for splashes, **protective gloves** with good insulation properties made of dry material that is not brittle (as for example leather or Kevlar®) must be worn. The gloves should be loose-fitting so that they can be taken off quickly and easily when a cryogenic liquid has entered the gloves. Cuffs should be made in such a way that they prevent easy ingress of liquids.

In situations where splashing cryogenic liquid might reach the eyes, **face protection** must be worn, e.g. when cryogenic liquid is transfused, pipelines are connected or disconnected or when parts are immersed into the cryogenic liquid. Goggles offer only incomplete protection.

When handling cryogenic liquids, **shoes** in good repair with treaded soles must be worn. When handling combustible cryogenic gases or liquids (e.g. liquid hydrogen, liquid natural gas, LNG) shoes with conductive ("antistatic") soles must be worn. All protective footwear manufactured according to EN 345 comply with these requirements but only if they still have the original soles. High boots are not advisable as they cannot be taken off quickly enough



Respiratory protective equipment might be necessary when the oxygen in the air is displaced by evaporated cryogenic gases. See also safety notes on **oxygen deficiency**.

3.2 Special requirements when handling cryogenically liquefied gases

Cryogenically liquefied gases are generally in a boiling state at atmospheric pressure. When **transfusing** gases into vessels that still have ambient temperature, the boiling initially increases considerably. In the course of this process, the cryogenically liquefied gases may easily splash in conjunction with the evaporating cryogenic gas. For this reason, face and hands must be protected. The same applies to the **immersion** of objects with ambient temperature (or warmer) into cryogenically liquefied gases.

Once the vessels or objects have reached the temperature of the cryogenically liquefied gas, evaporation decreases but the cryogenically liquefied gas remains in a **boiling state**. The heat intake causes the cryogenic gas to leak continuously from the vessel if it is open (e.g. in the case of a dewar). If the vessel is closed, the pressure will rise. The better the insulation of the vessel the slower the **pressure** increase will be.

One litre of cryogenically liquefied gas produces considerable amounts of gas (see table, row 6). Therefore, places where cryogenically liquefied gases in open vessels are handled must be provided with technical **ventilation** equipment that can at least safely divert the developing gas. Sufficient ventilation prevents the oxygen content of the air from changing substantially.



Oxygen enrichment of the air of (normally) 21 percent/Volume to more than approx. 23 percent/Vol. increases the **fire hazard** considerably. Cryogenically liquefied oxygen must therefore not be stored in open vessels.

Although it is true that the cryogenic gases listed in the table do not lead to poisoning as they are non-toxic, these gases (except oxygen) could displace the oxygen in the air which can lead to **asphyxiation** if the oxygen is below 15 percent/Vol.

It should be noted that even low concentrations of carbon dioxide in the air can lead to considerable **breathing disorders**. CO₂-concentrations of around 8 percent/Vol. and above are lethal within seconds.



Further information in this respect can be found in the safety notes: **Oxygen deficiency** and/or **oxygen enrichment**.

Staying in an environment that is supercooled by cryogenic gases can **reduce the body temperature** but breathing in this supercooled air can furthermore lead to lung activity disorders.

When cryogenic gases are mixed in the air, the cooling down of the air can lead to the development of fogs because the **air humidity** condenses. If large amounts of cryogenically liquefied gases are discharged, the developing fog can be so extensive that **visibility is reduced** to an extent hindering orientation. Please note that even outside the fog bank the composition of the air can change considerably.



At the boiling temperature indicated, all gases listed in the table are considerably heavier than air. In places where large amounts of cryogenically liquefied gases could be released, all drains must be provided with a liquid seal, there must be no open cellar windows or any other **open access to lower rooms**, conduits etc. as the heavy gases could accumulate there. In such areas there could be a particularly high asphyxiation and/or fire hazard. **Inert gases** (such as nitrogen, argon, helium, CO₂) do not present a fire hazard. These gases can even be used to extinguish fires.

A fire or explosion hazard can arise from leaking combustible cryogenically liquefied gases (such as liquid hydrogen, LNG) because they will evaporate and thus form an explosive mixture in combination with air. For this reason, effective natural or artificial ventilation is generally necessary. Although not combustible itself, oxygen enhances combustion considerably.

Materials considered un-combustible or flame-retardant under atmospheric conditions, may be combustible in oxygen-enriched air – even more so in pure **oxygen**. Once they are ignited, they burn extremely strongly, developing considerable heat. Materials combustible in air (such as oil, tarmac, plastics, ...) react with explosive force in combination with oxygen-enriched air and in pure oxygen. Therefore, contact with such materials must be avoided. Also see safety notes on **oxygen enrichment**



All cryogenic gases with a temperature below the boiling point of oxygen (see table, row 2) can, when handled, lead to a condensation of oxygen in the air and thus to local oxygen enrichment. See safety notes on **oxygen enrichment**.

Only materials that do not **brittle** in the cold may come into contact with cryogenically liquefied gases. Materials suitable for the low temperatures of these gases are for example copper, austenitic steel and some aluminium alloys.

Among plastics, PTFE is suitable under certain conditions. Which materials are suitable in each case should be clarified with the gas supplier.



If cryogenically liquefied gases can be trapped between two valves, **pressure release systems** with a sufficiently large diameter must be provided.

These liquids will evaporate even with the best insulation.

Any gas developing that way must be discharged in order to avoid pipes bursting

Before cryogenically liquefied gases enter devices, vessels, pipelines, fittings, etc., these must be completely dry. Otherwise, the cryogenically liquefied gases would cause the **humidity** to freeze and this in turn can lead to malfunctions (e.g. of safety valves, pressure gauges, ...).



Attention should be paid to the fact that any material shrinks when exposed to low temperatures. The extent of **shrinkage** depends on the material and on the temperature drop. When different materials shrink to a different extent, parts such as screwed flanges or similar connections may leak or break.

4. Transport

In particular when transporting cryogenically liquefied gases the precautionary measures described previously must be complied with. When a transport vessel filled with liquid nitrogen topples in a closed vehicle without ventilation, large amounts of gaseous nitrogen are suddenly released, displacing the aerial oxygen in the vehicle. Apart from that, the condensed air humidity (fog formation) leads to reduced vision inside the vehicle. As a result, both securing the load and ventilation have high priority when transporting cryogenically liquefied gases in vehicles.

5. Environmental protection

All the gases listed in the table (except hydrogen and LNG) are – in different concentrations – to be found in the air. When relatively small amounts (a few litres) of cryogenically liquefied gases evaporate into the atmosphere, this does not stress nor modify the environment for an extended period of time.

When cryogenically liquefied gases are spilled accidentally, this does not lead to a contamination of the ground, because cryogenically liquefied gases evaporate quickly, thus seeping into the soil to a low extent. Temporary freezing of the soil does not result in permanent damage to the soil.



6. Concluding remarks

Cryogenically liquefied gases can only be handled safely, when users have knowledge of the specific properties of these gases and use them sensibly. Misuse of cryogenic gases can cause harm such as frostbite, while the appropriate use of these gases is beneficial in cryosurgery. In other words: Cryogenically liquefied gases have neither good nor bad properties. What matters is that their properties are used correctly. Your gas supplier will tell you how.

IGV

This publication corresponds to the state of technical knowledge at the time of publication. It is the users' own responsibility to check the applicability in their particular case and the topicality of the information at hand. IGV and those who were involved in the preparation of the present publication do not assume any liability.

Industriegaseverband e.V. – Komödienstr. 48 – D-50687 Köln
 Phone: +49- (0)221-9125750
 Fax: 0221-912575-15 – Email: Kontakt@Industriegaseverband.de
 Internet: www.Industriegaseverband.de

IGV – Safety advice:
 The original is in German language
 Translations into other languages may be carried out by a qualified translation company

3.2 Note
Road Transportation**INFORMATION FOR ROAD TRANSPORTATION**
CRYOGENIC LIQUEFIED GASES: suffocating

non-toxic, non-caustic, non-inflammable, non-oxidizing – designation of the medium is indicated on the next page

HAZARDS

Heating results in pressure increase – danger of bursting.
Gas is having a suffocating effect without any observable symptoms.

The leaked liquid is very cold and evaporates rapidly.
Liquid causes heavy injuries through frostbite on skin and eyes.

Together with humid air, it generates fog.

Gas is heavier than air and spreads on the ground.

PROTECTIVE EQUIPMENT

Safety glasses, protective gloves or face protection, protective shoes

EMERGENCY MEASURES: IMMEDIATELY NOTIFY FIRE BRIGADE AND POLICE

Stop the motor.

Secure the road and warn other road users.

Keep unauthorized persons away from the danger zone.

Stay on wind side.

LEAKAGE LOSSES

If possible, remove leakage losses.

Consult an expert.

Have leaked liquid evaporated.

Warn everyone - danger of suffocating existing in sewerage, cellars and pits.

FIRE:

In case of fire conditions, cool the tank by means of a water spray jet.

FIRST AID:

Thaw frozen garments and remove them carefully.

Medical aid is required in case of frostbite symptoms.

ONLY VALID FOR ROAD TRANSPORTATION

3.3 Labelling

The tanks have to be labelled according to the regulations for hazardous goods for the respective employment.

Cryogenic liquefied Gases

suffocating, Class 2 Figure and Group 3A

Figure and Group	Number, Labelling, Designation of the Medium
3A	1977 nitrogen, cryogenic liquid 1951 argon, cryogenic liquid

Caution Marks

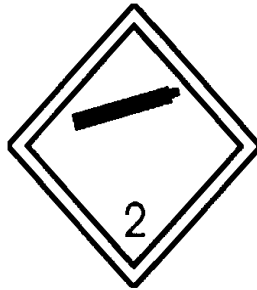

No. 2
Non-combustible
and non-toxic
gas;

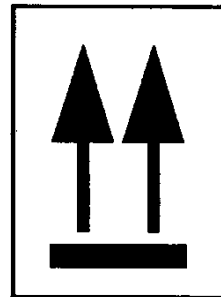

No. 11
This side up;
This label has to
be attached with
the arrow heads
pointing upwards.

4 Transportation and Assembly

4.1 General Transportation

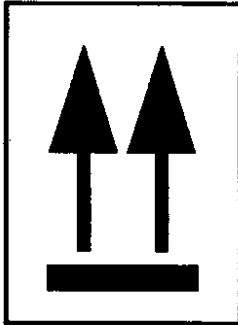

Transportation of the Vessel

- Observe safety instructions.
- Keep upright.
- Lift and set down carefully.
- Avoid impacts and strong shocks

Transportation in filled condition

- The vessel must be in excellent condition.
- Use 2 person for transport over inclines, pitches and steps



Observe the national regulations during internal and road transportation with vehicles. At the same time, protect the vessel from tumbling down, shifting and damage (by stowing / lashing).

4.2 Assembly



Assembly of the Vessel

- Observe safety instructions.
- Ensure good ventilation.
- Consider place of operation
- Fix castors by means of the locking levers.

4.3 Transport valve for APOLLO® receptacle

For capacitive level indicator (C-Stic) must be avoided that the EK-Head is not supposed to be disassembled from the APOLLO® in order to avoid the penetration of humidity into the level indicator. For an open transport the transport valve, which is located nearby the pressure gauge, has to be opened and blocked with the blocking device.

If the receptacle should be transported it has to be depressurized first. For this the exhaust ball valve has to be opened carefully. After that the transport valve has to be opened and the blocking device has to be turned that the text "Transport. Valve opened." is readable. Afterwards the blocking device has to be positioned behind the hand wheel of the transport valve so that unintentional closing is avoided. Now the APOLLO® receptacle can be transported in open condition.

After transporting the receptacle, turn the blocking device that the text „ Operating under pressure. Valve closed.“ is readable. The blocking device can be hung at the spindle of the transport valve. Close the valve and pressurize the receptacle as normal. The APOLLO®-receptacle is ready to use.

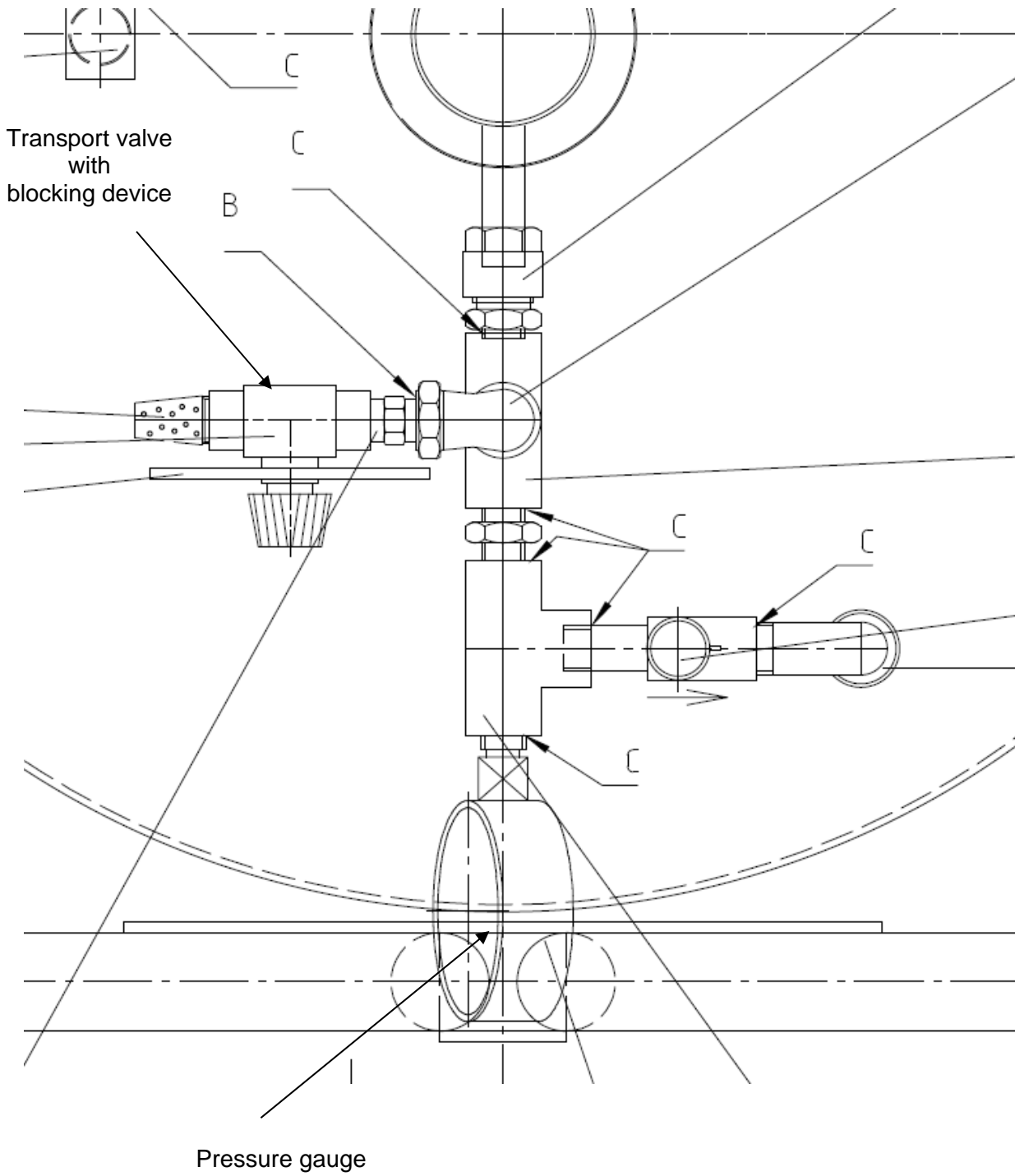

Behälter unter Druck.
Transportventil geschlossen.

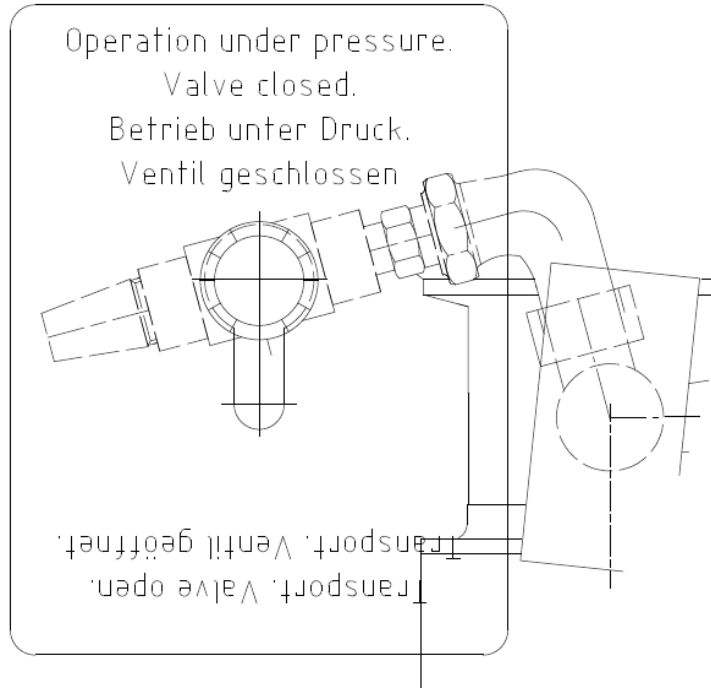

Behälter während Transport.
Transportventil geöffnet.

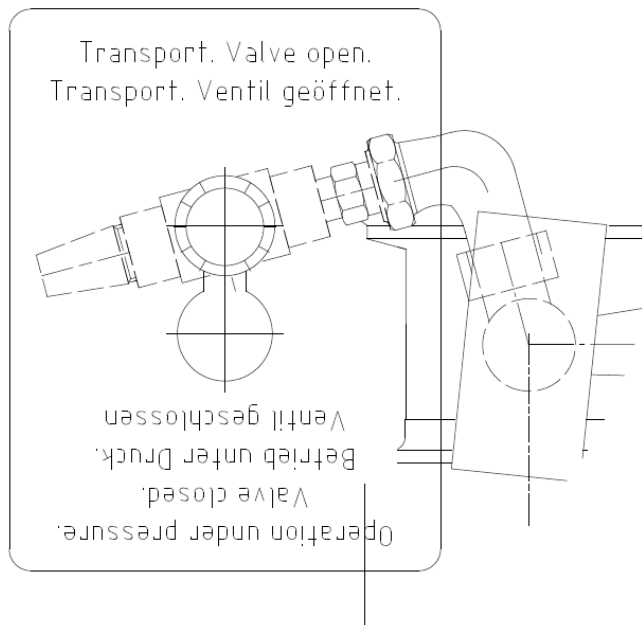

5 Operation

5.1 Initial Commissioning

The vessel can be commissioned immediately after delivery.



Caution !

- Observe safety instructions.
- Use filling line with safety valve and pressure relief.
- Wear gloves and safety glasses.
- Protect the vessel from rolling away, tumbling down and damage.



Note !

- When cooling down the hot vessel to operating temperature, increased evaporation losses do occur.

5.2 Assembly and Disassembly of the EK Siphon

In principle, operate the vessel exclusively by means of the EK Siphon (2).

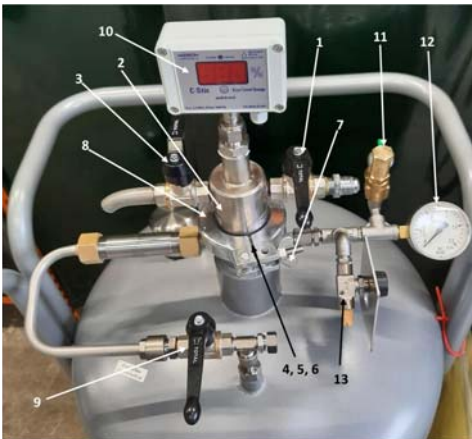

When opening the waste gas/overflow valve (3), make sure that it is not directed towards any persons or devices; cryogenic gas will cause burns and brittleness.



When opening the waste gas/overflow valve (3), make sure that it is not directed towards the positive pressure relief and seal-off device. Cryogenic gas may cause undercooling of the o-ring and vacuum damage.



Note !

- Due to operation, open valves will get covered by ice during the pressure build-up, waste gas/overflow and filling/withdrawal.
- Closed valves will thaw eventually.
- Lasting frost formation indicates leakage.

Assembly of the EK Siphon

1. Clean and remove ice from the sealing surfaces (4), centering ring (5) and O-ring (6) **and replace if damaged**.
2. Place the centering ring (5) with O-ring (6) on the flange.
3. Close the filling/withdrawal valve (1) at the EK Siphon.
4. Open the waste gas/overflow valve (3) for avoiding pressure increase.
5. Insert the EK Siphon (2) vertically into the neck.
6. Place the straining ring (8) and tighten the wing screw (7).
7. Close the waste gas/overflow valve (3).

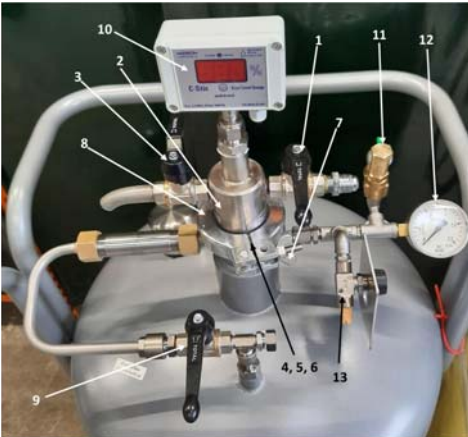

Liquid nitrogen may escape from the waste gas/overflow valve (3) when the EK Siphon is immersed.

Disassembly of the EK Siphon



Danger of Accidents!
Dismantle the EK Siphon only with unpressurized vessel.

1. Close the pressure build-up valve (9).
2. Close the filling/withdrawal valve (1).
3. Detach the connected withdrawal line from the EK Siphon.
4. Open the waste gas/overflow (3) valve for relieving the pressure of the vessel.
5. Loosen the wing screw (7) and remove the straining ring (8) from the unpressurized tank.
6. Remove the EK Siphon (2) by pulling it out carefully from the top and deposit it carefully.
7. Loosely insert the transport stopper.

5.3 Assembly of the Transfer Hose



Note

- Avoid any heavy mechanical strain.
- Do not carry out any assembly and disassembly while the vessel is cold.

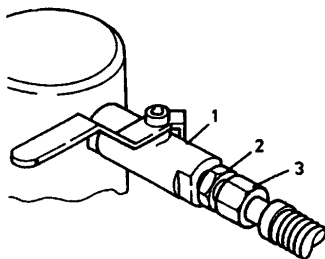

Assembly of the Transfer Hose

1. Screw the Filling/withdrawl Valve (1)
2. Screw the union nut (3) onto the connecting screwing (2) of the filling/withdrawal valve (1).
3. Tighten the union nut (3) by means of an open-jawed wrench (SW24); in doing so retain the hexagon (2) with a wrench (SW22).
4. If necessary, tighten the union nut (3) in cold condition.

5.4 Filling of the Vessel



Caution !

- Observe safety instructions.
- Use filling line with safety valve and pressure relief.
- Wear gloves and safety glasses.
- Protect the vessel from rolling away, tumbling down and damage.
- The pressure in the supply – vessel must not be higher than 1,3 bar



Note !

- Additional aggregates for filling and withdrawal have to be adapted to the operating conditions of the vessel.
- Filling has to take place outside or in a sufficient ventilated room



Risk of suffocation

Filling

1. The EK Siphon must be mounted.
2. Screw the Filling/withdrawl Valve (1)
3. Connect the filling line from the tank to the filling/withdrawal valve (1).
4. Open the waste gas/overflow valve(3) for causing pressure relief.
5. Open the filling/withdrawal valve (1) at the EK Siphon.
6. Open the tank valve for filling the vessel.
7. Observe level indicator (10)
8. Close the tank valve when liquid nitrogen escapes from the waste gas/overflow valve (3).



Caution!

Risk of skin burns

After completion of filling:



Waste Gas/Overflow Valve (3) to leave open.

1. Close the filling/withdrawal valve (1) at the EK Siphon (2).
2. Relief pressure from the filling line.
3. Loosen the filling line.
4. Move the tank to its destination with the Gas/Overflow Valve(3) and Transport Valve(13) opened.
5. Once reached the destined place, please close the Gas/Overflow Valve(3) and Transport Valve(13).
6. Vessel is ready to be operated.



Risk of skin burns by escaping nitrogen



Caution!
Risk of skin burns by escaping nitrogen

5.5 Withdrawal of liquid Nitrogen



Withdrawal

1. Move the vessel to the place of withdrawal with waste gas/overflow valve(3) and the Transport Valve(13) opened.
2. Mount the delivered transfer hose or a relevant filling line.
3. Close the waste gas/overflow valve(3) back
4. Open the filling/withdrawal valve (1) in order to withdraw liquid nitrogen.
5. Adjust the desired withdrawal pressure and open the pressure build-up valve (9) for this purpose.



Caution !

- Observe safety instructions.
- Wear gloves and safety glasses.
- Protect the vessel from rolling away, tumbling down and damage.

5.6 Pressure Build-up

The operating pressure in the vessel allows for withdrawing the liquid gas.

Vessel name		Apollo®
maximum operating pressure		1,3 bar

The safety valve limits the maximum operating pressure. Should the pressure in the tank not be sufficient for the withdrawal operation, it can be increased by opening the pressure build-up valve.



Prior to pressure build-up:

- Check the EK Siphon for tight seat.
- Adjust the operating pressure only as high as required.

Pressure Build-up

1. Close the waste gas/overflow valve.
2. Close the filling/withdrawal valve.
3. Slowly open the pressure build-up valve.
4. Watch the pressure gauge.
5. Close pressure build-up valve when the desired pressure is reached.

Continuous Withdrawal under constant Pressure

1. Slightly open the pressure build-up valve.
2. Close the pressure build-up valve when the desired pressure is reached.
3. When starting with the withdrawal, watch the pressure drop at the pressure gauge.
4. Open the pressure build-up valve in such a way that the desired pressure remains constant.



Note

- Avoid blowing-off of the safety valve.
- Frost formation on the vessel bottom is operational.



Close the pressure build-up valve prior to finishing the withdrawal process.

A pressure control valve is recommended for continuous withdrawal. This item has to be indicated separately on the purchase order. Retrofitting is possible.

5.7 Pressure Relief

Open the waste gas/overflow valve, until the operating pressure at the pressure gauge will be achieved. Subsequently, close the valve again.



Do not direct the opening of the waste gas/overflow valve towards any persons or devices, as cryogenic gas causes burns and brittleness.

5.8 Putting out of Operation

When putting the vessel out of operation, it has to be completely emptied out, warmed up and stored under slight gas overpressure, in order to avoid condensation of humidity.

5.9 Operating Instructions

OPERATING INSTRUCTIONS
APOLLO®/SATURN® with C-Stic

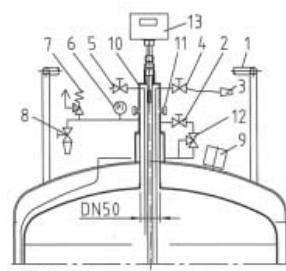

<p>1 Valve protection</p> <p>2 Press. build-up valve</p> <p>3 Filling hose with phase separator</p> <p>4 Filling/tapping valve</p> <p>5 Waste gas/overflow valve</p> <p>6 Pressure indicator</p> <p>7 Safety valve</p> <p>8 Transport valve & blocking device</p> <p>9 Vacuum shutter & safety valve</p> <p>10 EK siphon</p> <p>11 Eccentric and straining rings</p> <p>12 Pressure build up control valve optional</p> <p>13 Capacitive - Level indicator (C-Stic)</p>	<p>1. Safety</p> <ul style="list-style-type: none"> - Observe Code of Practice "Handling Nitrogen" - Operation only by trained staff (TRB700) - Loosen eccentric & straining ring (item 11) only with vessel depressurized - With set-up in indoor locations make sure of adequate aeration (TRB610) <p>2. Filling the dewar</p> <ul style="list-style-type: none"> - Valve(2) closed - Connect filling line (3) to filling valve (4) - Open waste gas/overflow valve (5) - Open filling/tapping valve (4) - Terminate filling when liquid emerges from waste gas/overflow valve (5) - Close filling tapping valve (4) <p>3. Tapping the liquid</p> <ul style="list-style-type: none"> - Connect filling hose (3) with phase separator to valve (4) - Open tapping valve (4) - Close valve (4) on completion of tapping
---	--

Art. Nr. 7822576

E				Werkstoff:			Alle mit Sauerstoff in Berührung kommenden Teile öl- und fettfrei
D				Werkstückkanten	Maßstab	Allgemeintoleranzen	Ahnl.:
C				-0.5	1:1	DIN 7168	Masse
B				+0.3	()	fein	kg
A	6168	22.04.2028	Haase	außen	Datum	25.10.18	Ers.d.:
A	And.Mitglg.	Datum	Bearb.	Innen	Bearb.:	be	Cryotherm
Diese Zeichnung ist urheberrechtlich geschützt. Sie darf ohne unsere ausdrückliche Zustimmung weder vervielfältigt noch in irgendeiner Weise weiterverbreitet oder Dritten mitgeteilt bzw. weitergegeben werden.				ISO-Methode	Gepr.:	Norm:	
Cryotherm GmbH & Co. KG				Bezug / Projekt:	APOLLO-SATURN		ZA Gegenstand Werk Gebäude
				Benennung:	OPERATING INSTRUCTION		Blatt-Nr.: 02 Blattzahl: 02
					Sach-Nr.:	78222573	F Z
							E

Dateiname: H:\SKIZZEN\78222573E02 Kurzbetriebsanleitung APOLLO SATURN mit C-Stic_5Kdwg Plotdatum:



Note !

The operating instructions

- are firmly attached to the outer vessel.

6 Maintenance / Repair

- With conventional use, the vessel does not require any special maintenance or attendance.
- Regular examinations with regard to operativeness and tightness of the fittings and screwings are recommended.
- Every two years, the safety valves have to be examined with regard to function and set pressure. The pressure gauge indicates the set pressure.

7 Faults

7.1 General Faults



Immediately put the vessel out of operation, in case that

- the fittings are leaky.
- the safety valve does blow off intensively.
- the rate of evaporation is too high.
- The outer cylinder is thawed / iced-up, which indicates loss of vacuum.



In case of nitrogen escaping,

- there exists the danger of suffocation.
- open windows and doors.
- leave closed rooms.



Vessels with vacuum loss are useless and have to be returned to the manufacturer for examination / repair.

In case of any queries, please indicate

- type of vessel
- maker's number
- year of construction

7.2 Possible Faults

Fault	Cause	Trouble shooting
Iced-up valve	<p>This is operational with opened valve.</p> <p>The valve is not closed completely.</p> <p>The valve is leaky.</p>	<p>-</p> <p>Close the valve (it thaws).</p> <p>Tighten the screwings / seat. If required, rinse / exchange the valve.</p>
Safety valve blows off.	<p>Pressure build-up valve is open.</p> <p>Pressure raising controller is too highly adjusted.</p> <p>Filling pressure is too high.</p> <p>Pressure build-up valve is open</p> <p>Level indicator is defective.</p>	<p>Close pressure build-up valve.</p> <p>Lower adjust the opening pressure of the pressure raising controller.</p> <p>Decrease the filling pressure of the withdrawal tank.</p> <p>Open waste gas overflow valve.</p> <p>Close shut-off valves of the level indicator, exchange level indicator.</p>
<p>Frost formation on the vessel</p> <ul style="list-style-type: none"> • at the outer vessel • at the bottom 	<p>Vacuum loss</p> <p>Operational pressure build-up</p>	<p>Examination / re-evacuation by the manufacturer</p> <p>-</p>
Positive pressure relief and seal-off device released, vessel extremely iced-up	Vacuum loss within the vacuum room	<p>Empty out the vessel / put it out of operation</p> <p>Examination / repair at the manufacturer's works</p>

8 Warranty

Our warranty requires the proper use of the device according to the regulations. When exchanging parts, only original spare parts have to be used. Wear parts are not subject to warranty.

Extent and duration of our warranty comply with the regulation indicated in our terms of delivery.

Behälter nach Richtlinie 2014/68/EU Vessel acc. to Directive 2014/68/EU		Cryotherm	
Kategorie category	I		
Typ type	APOLLO® 50 - 1,3 bar		
Herstell - Nr. fabr. no.	<input type="text"/>		
Baujahr year of construction	<input type="text"/>		
Leergewicht empty weight	<input type="text"/> kg		
CE	zul. Betriebsüberdruck working pressure	Innenbehälter inner vessel	Außenbehälter outer vessel
	tiefste Betriebstemp. working temperature	1,3 bar	-1 bar
	Fluid fluid	-196 °C	+20°C
	UN - Nr. UN - no.	LIN	<input type="text"/>
	Inhalt volume	<input type="text"/>	<input type="text"/>
		50 l	<input type="text"/> l
www.cryotherm.de			
Made in Germany Cryotherm GmbH & Co. KG 57548 Kirchen (Sieg)			

Behälter nach Richtlinie 2014/68/EU Vessel acc. to Directive 2014/68/EU		Cryotherm	
Kategorie category	I		
Typ type	APOLLO®100- 1,3 bar		
Herstell - Nr. fabr. no.	<input type="text"/>		
Baujahr year of construction	<input type="text"/>		
Leergewicht empty weight	<input type="text"/> kg		
CE	zul. Betriebsüberdruck working pressure	Innenbehälter inner vessel	Außenbehälter outer vessel
	tiefste Betriebstemp. working temperature	1,3 bar	-1 bar
	Fluid fluid	-196 °C	+20°C
	UN - Nr. UN - no.	LIN	<input type="text"/>
	Inhalt volume	<input type="text"/>	<input type="text"/>
		100 l	<input type="text"/> l
www.cryotherm.de			
Made in Germany Cryotherm GmbH & Co. KG 57548 Kirchen (Sieg)			

Behälter nach Richtlinie 2014/68/EU Vessel acc. to Directive 2014/68/EU		Cryotherm	
Kategorie category	I		
Typ type	APOLLO®150 - 1,3 bar		
Herstell - Nr. fabr. no.	<input type="text"/>		
Baujahr year of construction	<input type="text"/>		
Leergewicht empty weight	<input type="text"/> kg		
CE	zul. Betriebsüberdruck working pressure	Innenbehälter inner vessel	Außenbehälter outer vessel
	tiefste Betriebstemp. working temperature	1,3 bar	-1 bar
	Fluid fluid	-196 °C	+20°C
	UN - Nr. UN - no.	LIN	<input type="text"/>
	Inhalt volume	<input type="text"/>	<input type="text"/>
		150 l	<input type="text"/> l
www.cryotherm.de			
Made in Germany Cryotherm GmbH & Co. KG 57548 Kirchen (Sieg)			

Cryotherm

Cryotherm GmbH & Co. KG, certified according to DIN EN ISO 9001:2015
Article No. :• 78222574 • 2092
Subject to changes
©Cryotherm GmbH & Co. KG
® registered Trademark



Cryotherm GmbH & Co. KG Germany
Euteneuen 4
D-57548 Kirchen (Sieg)
Tel.: (0049-2741) 9585-0 • Fax (0049-2741) 6900

ZERTIFIKAT / CERTIFICATE
Konformitätserklärung / Declaration of Conformity
nach Richtlinie / acc. to Directive 2014/68/EU

Name und Anschrift des Herstellers: Name and adress of Manufacturer:	CRYOTHERM GMBH & CO.KG Euteneuen 4 57548 Kirchen (Sieg)
Zertifiziert durch/ Certified by:	TÜV Rheinland-Zertifizierungsstelle für Druckgeräte der TÜV Rheinland Industrie Service GmbH Am Grauen Stein 51105 Köln

Hiermit wird bescheinigt, daß die Ergebnisse, der an der unten genannten Baugruppe von Druckgeräten vorgenommenen Prüfungen, die Anforderungen der Richtlinie 2014/68/EU erfüllen. Das Typenschild ist mit dem abgebildeten Zeichen gekennzeichnet.
With this declaration, we certify that the results of the examinations carried out at the assembly of pressure devices mentioned below, the requirements of Directive 2014/68/EU.
The nameplate is marked with the depicted sign.



Geprüft nach Richtlinie Examined acc. to Directive	2014/68/EU
Kategorie / Category:	I
Angewandte techn. Spezifikationen: Applied technical specifications:	AD 2000
Modul / Module:	A
Beschreibung der Baugruppe: Description of the assembly:	<input type="checkbox"/> APOLLO® 50 <input type="checkbox"/> APOLLO® 100 <input type="checkbox"/> APOLLO® 150
Verwendungszweck: Description of pressure equipment:	LIN Lagerbehälter Storage vessel
Herstellnummer: Manufacturing no.:	
Baujahr : Year of construction:	

Kirchen,

Cryotherm GmbH & Co. KG

Druckgeräte der Baugruppe Assembly of pressure device	Herstellnummer Manufacturing no.	PS [bar]	TS [°C]	V [L]	Fluid	Fluidgruppe Fluids group	Kategorie Category	Kennzeichnung Labeling
APOLLO®		1,3	-196		LIN	2	I	CE
Sicherheitsventil Typ 06002		1,3	-196	-	LIN	2	IV	CE 0045

Ausrüstungsteile gem. Art.4, Abs.3 der Richtlinie 2014/68/EU
equipment accessories according to Art.4, Abs.3 directive 2014/68/EU

- | | |
|--|--|
| <input checked="" type="checkbox"/> EK Heber
withdrawal head | <input type="checkbox"/> Druckregler
pressure regulator |
| <input checked="" type="checkbox"/> Füllstandsanzeige
level gauge | <input type="checkbox"/> Doppelentnahme
dual withdrawal |
| <input checked="" type="checkbox"/> Manometer
pressure gauge | <input type="checkbox"/> Dreifachentnahme
triple withdrawal |

Für die Aufstellung, Inbetriebnahme und den Betrieb des Behälters sind die nationalen Verordnungen, bei Aufstellungsort Deutschland zusätzlich die Betriebssicherheitsverordnung (BetrSichV) einzuhalten.

For set up, start up and operation of the vessel the national regulations are to be used. For vessels placed in Germany additional the Betriebssicherheitsverordnung (BetrSichV) has to be applied.