



User manual
High pressure safety stop
SP300-E

Contents

1 Introduction	3
2 Description	4
2.1 Intended use	4
2.2 Misuse	4
2.3 Identification / label	4
2.4 Environment.....	5
2.4.1 Temperatures.....	5
2.4.2 Degree of cleanliness	5
2.4.3 Emissions.....	5
2.5 Standards and laws.....	5
3 Safety	7
3.1 Basic information on the safety instructions.....	7
3.2 Safety instructions.....	8
3.3 Emergencies and safety devices	10
3.4 Qualification of the operating and maintenance personnel.....	10
4 Design and function	11
4.1 Design	11
4.2 Functional description	13
4.3 Technical data.....	14
4.4 Boundaries and interfaces	14
5 Installation	15
5.1 General information.....	15
5.2 Installation work	15
5.2.1 Connecting the incoming and outgoing lines	15
6 Commissioning	16
6.1 Preparations for commissioning.....	16
7 Operation	17
7.1 General information on operation.....	17
7.2 Resetting the SP300	17
8 Maintenance, cleaning and repairs	18
8.1 General information on maintenance	18
8.2 Regular maintenance work and cleaning	19
8.3 Regular maintenance work and cleaning	20
9 Repair	21
9.1 General information on repair work.....	21
9.2 Troubleshooting and fault rectification	22
10 Dismantling and disposal	23
10.1 General information on dismantling	23
10.2 Returns.....	23
10.3 Disposal	24

1 Introduction

This user manual is the original user manual for the Safety shut-off device SP300-E from Spectron Gas Control Systems GmbH, referred to as Spectron.

The user manual is intended to facilitate correct and safe operation for the operating firm, and to warn against misuse. It is intended for the qualified personnel and the operator of the facility.



WARNING

Incorrect operation

Incorrect operation of the system, e.g. due to instruction errors, can lead to personal injury or damage to the system.

- a) Access to the user manual by the operating and maintenance personnel must be absolutely ensured at all times.
- b) A copy of the system documentation including the user manual must therefore be kept either on the system or in a suitable and accessible location.

This user manual contains information protected by copyright law. It must not be photocopied, reproduced, translated or copied onto data carriers, either in full or in part, without prior authorisation. Spectron retains all further rights.

2 Description

2.1 Intended use

The high-pressure safety stop SP300-E is an indirect-action safety shut-off device (SSD) with outlet pressure actuation. The intended use is the immediate interruption of the gas flow between the gas source and downstream valves in the event of an impermissible increase in the outlet pressure.

A key feature is a relief valve built into the outlet pressure. By connecting the relief valve to a control pressure line, the SP300-E is driven with its own medium.

Safety shut-off devices of type SP300-E are suitable for flammable gases, non-flammable gases, oxygen and additionally also for use with corrosive and toxic gases and gas mixtures up to gas quality 6.0.

The permissible gas types and pressure ranges are each specified on the label (see "Identification / label").

The equipment versions of the Safety shut-off devices without electrical components may be used in an explosion hazard zone as they do not have separate ignition sources (ignition hazard assessment according to DIN EN ISO 80079-36).

To be able to use the Safety shut-off devices as intended, all persons working with it must comply with the specifications of the relevant user manual.

The area in which hazards can occur when used as intended is the area around the Safety shut-off devices. The danger zone changes depending on the system status and use.

2.2 Misuse

Any improper use constitutes misuse. Safety shut-off devices may only be used for the specified gases and in the specified pressure range. Safety shut-off devices with electrical components without marking according to EU Directive 2014/34/EU may not be used in an explosion hazard zone.

Furthermore, the following operating conditions are regarded as misuse:

- Use for gases in their liquid phase
- Failure to carry out inspection and maintenance work
- Pressurisation in reverse (opposite to the flow direction)
- Operation with gases that are not specified on the label
- Operation outside the permissible technical limit values
- Failure to heed and comply with any applicable legal regulations and other provisions
- Non-observance of the user manual
- Failure to heed the information on the label and in the product data sheet
- The renewed pressurisation in triggered status

2.3 Identification / label

The label is located on the on the body of the Safety shut-off device.

It provides the following details:

Details	Example
Manufacturer logo	Spectron
Town and country of the manufacturer	Frankfurt am Main, Germany
Serial number	140003852-202005-0001
Max. permissible pressure PS	300 bar

Gas type	Nitrogen
Flow coefficient Cv	2.2
Nominal width DN	DN5
Date of manufacture	2020/05
Standard	EN 14382
Type	SAE
Type	IS
Function class	A
Temperature class	2
CE labelling	CE0036



NOTICE

Leak and functional test

The high-pressure safety stop undergoes a leak and functional test before being shipped. The back of the housing is marked with a quality control stamp as proof.

2.4 Environment

2.4.1 Temperatures

Normal temperatures expected in a production area are assumed when operating the system: -20°C to +60°C.

The air humidity must be below 60 % rel. humidity to prevent condensation. The operating temperature depends on the gas used.

2.4.2 Degree of cleanliness

Access to the system and to the escape and rescue routes must not be blocked.

The product should be kept clean (dust-free).

A suitable purge gas must be used, taking into account the quality and properties of the process gas.

Compressed air must be used for the control air at least class 5 according to ISO 8573-1.

2.4.3 Emissions

The A-rated sound pressure level does not exceed the value of 70 dB(A). It is not necessary to wear hearing protection.

The waste gas line or a burst disc line must not end in areas where the escaping process gas poses a hazard to persons or the environment.

Further emissions in the form of vibrations, radiation, vapours, dusts and waste water do not occur in the regular operation of the product.

2.5 Standards and laws

The design and construction of the Safety shut-off device is subject to the following standards and directives:

2006/42/EC	Machinery Directive
2014/68/EU	Pressure Equipment Directive

2014/34/EU	ATEX directives
DIN EN ISO 12100:2010	Safety of Machinery
Safety data sheet for the gases used	Process gas and auxiliary media
<p>Various additional laws, regulations and guidelines must be complied with when handling pressurised gases. Find out about the laws, regulations and guidelines that apply in your location.</p>	
BetrSichV	Betriebssicherheitsverordnung (Industrial health and safety ordinance)
ProdSG	Produktsicherheitsgesetz (Product Safety Law)
GefStoffV	Gefahrstoffverordnung (Hazardous Substances Ordinance)
TRGS 400, 407, 500, 720, 721, 722, 727, 745, 746	Technische Regeln Betriebssicherheit (Technical Regulations on Operational Safety)
TRBS 1111, 2152, 3145, 3146	Technische Regeln Betriebssicherheit (Technical Regulations on Operational Safety)
DGUV Regulation 1	German Trade Association Principles of Prevention
DGUV Rule 113-001	German Trade Association Rules on Explosion Protection
EIGA documents	

3 Safety

3.1 Basic information on the safety instructions

The product complies with the recognised technical regulations. Nevertheless, knowledge of the media used and their dangers as well as basic knowledge of the pressure control panel are prerequisites for safe and accident-free operation.

The user manual must be read and understood by every user. Instruction must be documented in writing.

The safety instructions are to be regarded as a supplement to the applicable accident prevention regulations and laws. Existing accident prevention regulations and laws must be observed in all cases.



NOTICE

Hazards from the operating environment of the system can lead to injuries to persons.

- a) No changes may be made to the system which result in a change in function.
- b) It is not possible to outline and cover in this manual all hazards arising from the environment or unforeseeable operating conditions of the system.

In the Safety Instructions chapter:

- Users are informed regarding hazards, residual risks and measures for risk reduction.
- The presentation of the safety instructions and the symbols is explained.
- Basic safety instructions to be observed in general are listed. Specific safety instructions are listed in the relevant chapters.



⚠ DANGER

DANGER indicates an imminent danger. If not avoided, death or extremely serious injuries will result.



⚠ WARNING

WARNING indicates a potential imminent danger. If not avoided, death or serious injury could result.



⚠ CAUTION

CAUTION indicates a potentially imminent danger. If not avoided, minor or moderate injury could result.



NOTICE

NOTICE indicates a potentially harmful situation. If not avoided, the system or property in its vicinity could be damaged.

3.2 Safety instructions

The safety instructions are to be observed by all persons working on the system. The rules and regulations for accident prevention applicable to the place of use are to be observed. The instruction of the operating and maintenance personnel on system safety must be documented.

Please pay special attention to this chapter to avoid accidents.

All measures and specifications in the safety data sheets must be implemented and observed.



DANGER

Gas leaks

If gas escapes on the product, contamination of persons, fires or explosions or the displacement of atmospheric oxygen can occur! Serious or fatal injuries are possible.

- a) Do not place pipelines and fittings under mechanical stress. Never use pipelines and components as climbing aid or to secure other parts!
- b) In the event of leaks, immediately secure the affected area!
- c) Smoking and naked flame are strictly prohibited!



DANGER

Intended use

Operation of the product with gases other than those specified or outside the limits may result in dangerous reactions in the system. Incorrect use poses considerable risks to operating personnel and the environment!

- a) Only use the product for gases for which it was designed.
- b) Only use the product in the specified limit values for pressure and withdrawal quantity.
- c) Usage for another type of gas or outside the limit values is prohibited and constitutes misuse.



DANGER

Defective product

A defect on the product can result in unforeseeable operating conditions. Persons may be injured.

- a) The product may only be operated in technically perfect condition in compliance with all chapters of the user manual.
- b) Environmental protection laws and safety regulations must be observed.



WARNING

Displacement of atmospheric oxygen

In the event of inert gas leaks, displacement of atmospheric oxygen may occur. Danger of suffocation!

- a) The operator must ensure adequate ventilation and airing in all rooms with gas installations and monitor the oxygen content.

**⚠ WARNING****Repairs**

If the product is not used as intended, unpredictable operating conditions may occur. Serious personal injuries are possible.

- a) Repairs may not lead to a change in function. The system may not be tampered with or modified.
- b) Before each repair, the system must be depressurised and flushed through.
- c) Repairs are only permitted to be carried out by trained persons.

**⚠ WARNING****Incorrect operation**

Incorrect operation of the system, e.g. due to instruction errors, can lead to personal injury or damage to the system.

- a) Access to the user manual by the operating and maintenance personnel must be absolutely ensured at all times.
- b) A copy of the system documentation including the user manual must therefore be kept either on the system or in a suitable and accessible location.

**⚠ WARNING****Working on the product**

If an accident occurs when working on the product, there is a considerable risk of injury.

- a) Never work on the product unattended or unannounced.
- b) Observe the site safety rules and permission procedure.

**⚠ WARNING****Maintenance**

Incorrect maintenance or maintenance work performed at the incorrect time can result in damage to the system or injury to persons.

- a) To avoid static charges, do not clean the product using dry cloths. Use damp cotton cloths.
- b) The maintenance intervals are to be specified by the system operator as part of its risk assessment.
- c) Observe the maintenance intervals and maintenance guidelines from the manufacturer and the applicable guidelines.
- d) Components may only be replaced by spare parts of the same design. The specifications of the component manufacturers must be complied with during installation.

**⚠ CAUTION****Pressure relief lines**

Discharge of hazardous media at the end of a pressure relief line or exhaust air line.

- a) Pressure relief lines may not end in areas where the escaping process gas poses a hazard to persons or the environment.
- b) The position of the pressure relief line must be carefully checked taking into account the material properties, main wind direction and other conditions.



NOTICE

Lighting

Incorrect switching actions or confusion can occur due to inadequate lighting.

- a) Ensure sufficient lighting in accordance with the statutory regulations.

3.3 Emergencies and safety devices

The operational local safety regulations of the system operator, such as the alarm plan, fire safety regulations and the escape and rescue plans, apply in all cases for the operation of the Safety shut-off device .

When handling gases, all specifications from the safety data sheets must be followed. Local emergency services should be informed of the gases used at the site of the system.

In the event of mechanical damage, the product must be put into a safe operating condition.

3.4 Qualification of the operating and maintenance personnel

The intended user group is the system operator (user of the system) and the system maintenance personnel.

Every person working on the system must be familiar with the functions and dangers associated with the overall system. Instruction on the system is to be documented in writing.

Maintenance and repair work should only be carried out by specially trained personnel.

All operators, as well as personnel who regularly enter the area, must be trained on a minimum of the following topics:

- Alarm rules at the site and conduct in the event of malfunctions and leaks
- Basic functions of the product
- User manual
- System documentation incl. manufacturer documentation
- Position of the safety devices
- Safety data sheets on the process gas used
- Personal protective equipment

In addition, operators must have the requisite physical and mental skills to operate and maintain the equipment.

Persons who do not meet this requirement (e.g. visitors), must not remain alone in the overall system.

Operating personnel must use appropriate personal protective equipment for the activities to be performed and the associated environmental hazards. The operational instructions and the specifications of the employers' liability insurance associations and the safety data sheets must be complied with.

4 Design and function

4.1 Design

Illustration of the pressure control panel with gas cylinder connected

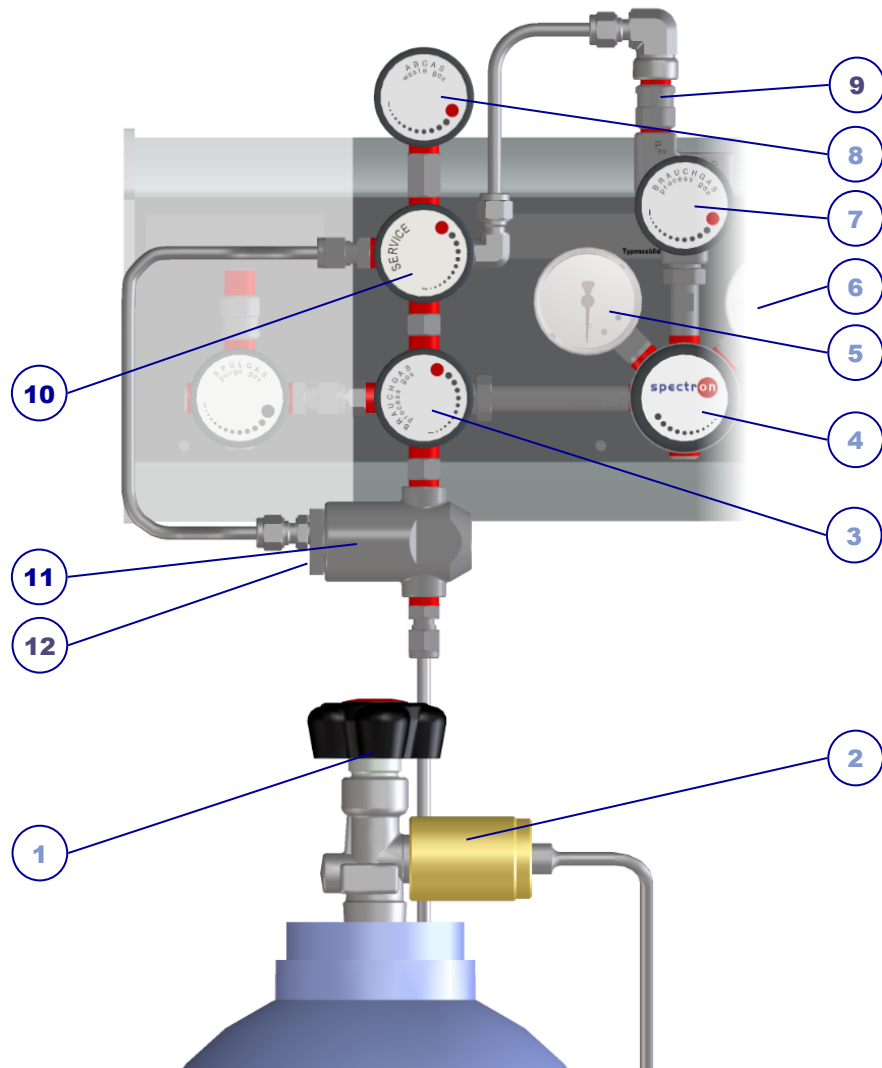

Illustration 1: SP300S design mounted onto pressure control panel with purge device

Pos.	Designation	Short name	Connection
1	Process gas source valve		
2	Cylinder connection incl. plug		Cylinder connection (see label)
3	High-pressure process gas shut-off valve	HPI	
4	Pressure regulator	PR	
5	Pre-pressure gauge	PG P1	
6	Outlet pressure gauge	PG P2	
7	Process line isolation on low pressure side	PLI	
8	High-pressure waste gas valve	HPV	

9	Non-return valve on relief valve	NRV3	
10	Service valve	S	
11	High pressure safety stop with marking	SP300	Compression ring fitting 6x1 mm
12	Grub screw		



NOTICE

The SP300 operates fully automatically with internal auxiliary energy, which is extracted from the process gas. No manual triggering option is provided.



NOTICE

The complete triggering is indicated by a part of the closing piston with o-ring protruding from the SP300. If only part of the closing piston is visible and the o-ring is not visible, partial triggering is carried out. This situation represents a defect in the SP300. It must be corrected in accordance with "Resetting the SP300 [▶ 17]".

4.2 Functional description

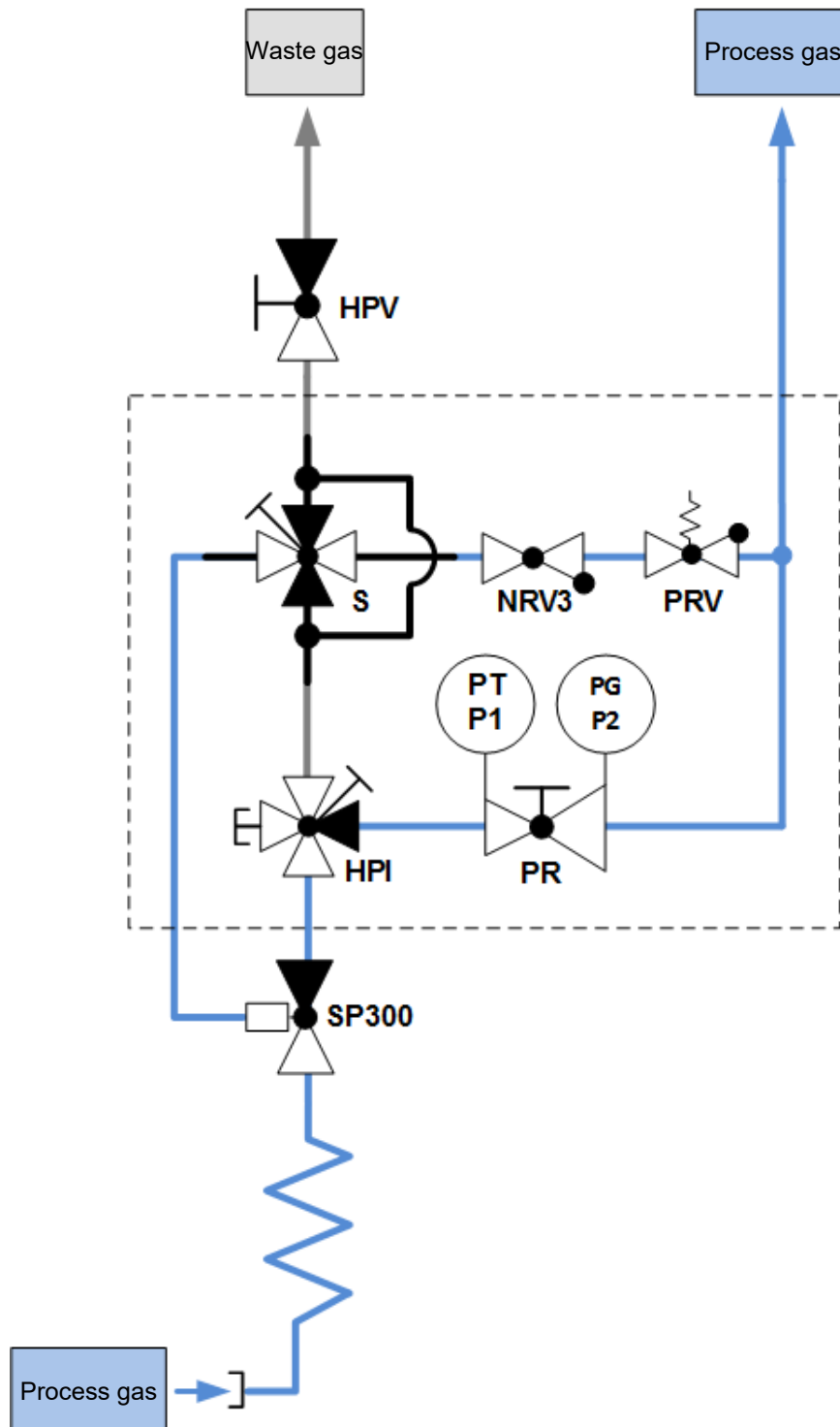

Illustration 2: P&ID BE55-1-SP300S

The high-pressure safety stop SP300-E is an indirect-action safety shut-off device (SSD) with outlet pressure actuation. The intended use is the immediate interruption of the gas flow between the gas source and downstream valves in the event of an impermissible increase in the outlet pressure.

A key feature is a relief valve built into the outlet pressure. By connecting the relief valve to a control pressure line, the SP300-E is driven with its own medium.

4.3 Technical data



NOTICE

The technical data can be taken from the data sheet for the relevant product. If this is not available, you can view and download it at www.spectron.de.

The maximum input and output pressures and the gas type are given on the identification or label.

4.4 Boundaries and interfaces

The scope of supply includes the product as described in the "Design [▶ 11]" chapter. The transfer points to process gas, exhaust air and auxiliary media (incl. power supply) are the connections on the pressure control panel or product.

The following areas and functions have not been included in the scope of supply from Spectron:

- other systems, lines and installations of the overall system
- Process gas source
- Exhaust air (this applies in particular to foreseeable problems, e.g. failure of the exhaust air system)
- Supply of auxiliary media (compressed air, purge gas)
- Power supply
- Lighting
- Controller

5 Installation

5.1 General information



⚠ CAUTION

Injury or damage in the event of incorrect assembly or disassembly

Special steps are required for assembly and disassembly work on the product. Personal injuries and damage to the product are possible.

- a) Assembly and disassembly work may only be carried out by the installation engineer or appropriately skilled specialist companies and persons.
- b) The product is not permitted to be re-used following disassembly. All components must be disposed correctly.

Depending on the type of gas, different requirements apply to the installation space of gas supply systems. It is essential to observe the legal regulations and trade association regulations, and the information in the safety data sheets.

Familiarise yourself with the necessary work steps (see "Installation work [▶ 15]") and prepare the necessary tools.

See also

- 📖 Functional description [▶ 13]

5.2 Installation work

5.2.1 Connecting the incoming and outgoing lines

All lines must be connected in accordance with the applicable standards and specifications and tested with purge gas (pressure test and leak test). The specifications on dimensioning of the connections are described in the "Design [▶ 11]" chapter.



NOTICE

The pressure relief line cannot be discharged, as it is used to activate the safety shut-off device. Only the waste gas / exhaust air lines can be discharged.

The procedure and further instructions for installation, commissioning, operation and dismantling are described in the operating instructions of the pressure control panel.

6 Commissioning

6.1 Preparations for commissioning

The commissioning of the pressure control panel may only be carried out after the integration into the inventory has been completed. Commissioning is not permitted until the incomplete machine has been installed into a complete machine and this corresponds to the provisions of the EU Machinery Directive and the EC Declaration of Conformity according to appendix II A.

Before putting the equipment into operation for the first time, the entire pressure control panel must be purged via the PLI valve right up to the process. It is imperative to adhere to the direction of the gas flow when doing this. You must not purge counter to the usual direction of flow (from the tapping point to the pressure control panel), since this can flush debris resulting from the installation work, for example, back into the pressure regulator (PR).

The connecting threads and connecting surfaces of the gas source valves as well as the sealing rings must be checked to ensure that they are in perfect condition.

Always turn shut-off valves as far as the stop when opening or closing them.

Make sure that:

- the fittings are marked for the corresponding gas type,
- all protective caps have been removed,
- the assembly has been correctly carried out and a leak test has been performed,
- all valves are closed (the red marking is visible in the handwheel window)
- the pressure regulator has been depressurised (if possible),
- the purge gas supply (only standard for SP4 and SP6) is in operation,
- the on-site exhaust gas system is functional at all times and is in operation,
- all shut-off armatures are checked for loose connections and
- the controller is in operation.



WARNING

Do not open the gas source in triggered status!



NOTICE

The pressure relief line cannot be discharged, as it is used to activate the safety shut-off device. Only the waste gas / exhaust air lines can be discharged.

The procedure and further instructions for installation, commissioning, operation and dismantling are described in the operating instructions of the pressure control panel.

7 Operation

7.1 General information on operation

During regular operation, the system will be in supply mode. For information on general operation, refer to the operating manual for the pressure control panel.

If the outlet pressure is too high, the relief valve integrated on the pressure regulator opens. The outlet side of the relief valve is connected to the SP300 via a control line. If the pressure in the control line increases, the closing piston in the SP300 closes the supply line. All subsequent devices and fittings are no longer supplied with the medium used. In the triggered state, renewed pressurisation on the SP300 is prohibited!

The gas supply is only guaranteed again after the closing piston in the SP300 has been manually reset.



NOTICE

The pressure relief line cannot be discharged, as it is used to activate the safety shut-off device. Only the waste gas / exhaust air lines can be discharged.

The procedure and further instructions for installation, commissioning, operation and dismantling are described in the operating instructions of the pressure control panel.

7.2 Resetting the SP300

To return the closing piston in the SP300 to the original position, the gas line between the gas cylinder and the pressure regulator, as well as the control line, must be pressure-relieved:

- Close process gas source [1] valve.
- Open the exhaust gas valve [8].
- Open the service valve [10].
If there is no service valve on the pressure control panel, the pressure relief of the control line takes place via the grub screw (SW 3) [12]. The control pressure escapes into the environment.
- Push in the closing piston completely by hand as far as it will go.
- Close the exhaust gas valve [8] and service valve [10] or grub screw [12].

The station is now ready for use again - commissioning can taken place.

8 Maintenance, cleaning and repairs

8.1 General information on maintenance



⚠ WARNING

Noise emission

When working on pressurised pneumatic supply, significant noise emission can occur. Acute and chronic loss of hearing may result.

- a) Never perform work on the pressurised pneumatic supply without hearing protection.
- b) Only replace the silencers when the supply is unpressurised.



⚠ WARNING

Incorrect operation

Incorrect operation of the system, e.g. due to instruction errors, can lead to personal injury or damage to the system.

- a) Access to the user manual by the operating and maintenance personnel must be absolutely ensured at all times.
- b) A copy of the system documentation including the user manual must therefore be kept either on the system or in a suitable and accessible location.



⚠ WARNING

Working on the product

If an accident occurs when working on the product, there is a considerable risk of injury.

- a) Never work on the product unattended or unannounced.
- b) Observe the site safety rules and permission procedure.



⚠ WARNING

Maintenance

Incorrect maintenance or maintenance work performed at the incorrect time can result in damage to the system or injury to persons.

- a) To avoid static charges, do not clean the product using dry cloths. Use damp cotton cloths.
- b) The maintenance intervals are to be specified by the system operator as part of its risk assessment.
- c) Observe the maintenance intervals and maintenance guidelines from the manufacturer and the applicable guidelines.
- d) Components may only be replaced by spare parts of the same design. The specifications of the component manufacturers must be complied with during installation.



⚠ CAUTION

Injury or damage in the event of incorrect assembly or disassembly

Special steps are required for assembly and disassembly work on the product. Personal injuries and damage to the product are possible.

- a) Assembly and disassembly work may only be carried out by the installation engineer or appropriately skilled specialist companies and persons.
- b) The product is not permitted to be re-used following disassembly. All components must be disposed correctly.



NOTICE

Lighting

Incorrect switching actions or confusion can occur due to inadequate lighting.

- a) Ensure sufficient lighting in accordance with the statutory regulations.

Correctly performed and timely maintenance increases the service life, ensures availability and helps to avoid undesirable downtimes. Depending on the gas type, the components are subject to different maintenance intervals. Observe the stipulations from the applicable directives.

Servicing and maintenance measures are only permitted to be carried out by competent specialist companies and persons.

Maintenance work should be documented by the operator. The documentation should indicate who carried out which work and when (proof of maintenance).

It is only permitted to use original spare parts or equivalent spare parts as well as suitable tools:

The recommended maintenance and test intervals are to be observed! (Also observe the manufacturer's documents)

The causes of possible defects are to be investigated, e.g. damage, unusual noises, overheating, etc.

Before beginning maintenance work, the pressure control panel must be purged (see "Interruptions to operation for more than 48 hours"). After completing the works, a re-commissioning process must be carried out (see "Commissioning [▶ 16]").

8.2 Regular maintenance work and cleaning

For components in which the tests reveal wear or even malfunctions, repairs or component replacement must be carried out by competent specialist companies and persons.

Components	Test	Interval
Filter	Replace filter	Replacement with insufficient flow rate
All	Visual inspection for corrosion, damage and correct fastening Functional test Leakage test	At least annually and before each commissioning process
Earthing	Visual inspection for damage and correct fastening	At least annually

The product should be cleaned on a regular basis. Heavy soiling can lead to malfunctions.

Only clean the product as necessary using a damp, lint-free and clean cloth, without cleaning agent.

8.3 Regular maintenance work and cleaning

The product should be cleaned on a regular basis. Heavy soiling can lead to malfunctions. Only clean the product as necessary using a damp, lint-free and clean cloth, without cleaning agent.

It is generally recommended that the high-pressure safety stop is triggered once a year and that its closing piston is changed at intervals of 5 years. The steps required for this are described in the maintenance instructions.

9 Repair

9.1 General information on repair work



⚠ WARNING

Noise emission

When working on pressurised pneumatic supply, significant noise emission can occur. Acute and chronic loss of hearing may result.

- a) Never perform work on the pressurised pneumatic supply without hearing protection.
- b) Only replace the silencers when the supply is unpressurised.



⚠ WARNING

Incorrect operation

Incorrect operation of the system, e.g. due to instruction errors, can lead to personal injury or damage to the system.

- a) Access to the user manual by the operating and maintenance personnel must be absolutely ensured at all times.
- b) A copy of the system documentation including the user manual must therefore be kept either on the system or in a suitable and accessible location.



⚠ WARNING

Working on the product

If an accident occurs when working on the product, there is a considerable risk of injury.

- a) Never work on the product unattended or unannounced.
- b) Observe the site safety rules and permission procedure.



⚠ CAUTION

Injury or damage in the event of incorrect assembly or disassembly

Special steps are required for assembly and disassembly work on the product. Personal injuries and damage to the product are possible.

- a) Assembly and disassembly work may only be carried out by the installation engineer or appropriately skilled specialist companies and persons.
- b) The product is not permitted to be re-used following disassembly. All components must be disposed correctly.



NOTICE

Lighting

Incorrect switching actions or confusion can occur due to inadequate lighting.

- a) Ensure sufficient lighting in accordance with the statutory regulations.

The objectives of the repair are:

Detect and assess causes of malfunction

Rectify faults and restore operational readiness

Repairs to the product may only be performed by the manufacturer or specialist personnel instructed on the system.

Work on electrical system parts may only be performed by a qualified electrician.

Before beginning work, the pressure control panel must be purged (see "Flushing through to the process"). After completing the works, a re-commissioning process must be carried out (see "Commissioning [▶ 16]").

9.2 Troubleshooting and fault rectification

Fault	Possible cause	Remedy
Outlet pressure too low	Process gas source empty	Check inlet pressure on the pressure regulator and change the process gas source if necessary
Vibration noises in the pressure regulator	Pressure regulator faulty	Replace pressure regulator
Pressure regulator frozen	Flow rate too high	Reduce flow rate or use gas preheater if possible
System pressure cannot be set to the desired value	Pressure regulator faulty	Replace pressure regulator
	System pressure outside the intended system pressure	Only operate the system at the intended range
Flow insufficient or fluctuating	Inlet pressure of the process gas too low	Increase inlet pressure
	Valve faulty	Replace faulty valve
	Filter loaded	Change filter
Relief valve, over-pressure valve, safety valve or burst disc are discharging gas	Impermissible pressure rise in the outlet pressure range	Close all valves and check pressure control panel
HPI valve cannot be opened or closed	Pneumatic pressure too low	Check pneumatic pressure
	Compressed air hose ripped	Replace compressed air hose out
Leak	Connection leaking	Flush pressure control panel clear and perform pressure test and leak test

10 Dismantling and disposal

10.1 General information on dismantling



⚠ WARNING

Noise emission

When working on pressurised pneumatic supply, significant noise emission can occur. Acute and chronic loss of hearing may result.

- a) Never perform work on the pressurised pneumatic supply without hearing protection.
- b) Only replace the silencers when the supply is unpressurised.



⚠ CAUTION

Injury or damage in the event of incorrect assembly or disassembly

Special steps are required for assembly and disassembly work on the product. Personal injuries and damage to the product are possible.

- a) Assembly and disassembly work may only be carried out by the installation engineer or appropriately skilled specialist companies and persons.
- b) The product is not permitted to be re-used following disassembly. All components must be disposed correctly.



NOTICE

Lighting

Incorrect switching actions or confusion can occur due to inadequate lighting.

- a) Ensure sufficient lighting in accordance with the statutory regulations.

Before dismantling and disposal of the product, it must be taken out of operation and purged. The product must then be disconnected from the auxiliary media supply.

The dismantling process is to be carried out in the following order:

1. Purging of the product and decommissioning.
2. Disconnect the product from the gas supply system.
3. Disconnect the product from the process.
4. Remove the product – to do so, please refer to the "Installation [▶ 15]" chapter.
5. Seal all ports on the product.
6. Pack the product.

10.2 Returns

If products are returned to Spectron for checking, maintenance or repair, it is essential to purge them with inert gas. A check can only be undertaken by Spectron if the repair pre-registration including the decontamination declaration has been duly completed.

10.3 Disposal

Dismantling and disposal must be carried out in accordance with the official and legal requirements at the site of the system. The operator must produce a risk assessment and work instructions before dismantling. A piece of equipment may only be disposed of when the decontamination declaration has been provided, completed in full.



Gas control on a high level



Spectron Gas Control Systems GmbH
Monzastr. 2c
D-63225 Langen
Tel: +49 (0)6103 9424-050
Fax: +49 (0)6103 9424-072
info@spectron.de
www.spectron.de