



spectro lab



User manual  
High pressure panel  
BM50-1+2

# Contents

<b>1</b>	<b>Introduction</b>	<b>4</b>
<b>2</b>	<b>Description</b>	<b>5</b>
2.1	Intended use	5
2.2	Misuse	5
2.3	Identification / label	5
2.4	Environment	6
2.4.1	Temperatures	6
2.4.2	Degree of cleanliness	6
2.4.3	Emissions	6
2.5	Standards and laws	6
<b>3</b>	<b>Safety</b>	<b>8</b>
3.1	Basic information on the safety instructions	8
3.2	Safety instructions	9
3.3	Emergencies and safety devices	11
3.4	Qualification of the operating and maintenance personnel	11
<b>4</b>	<b>Design and function</b>	<b>12</b>
4.1	Design	12
4.2	Functional description	13
4.3	Technical data	13
4.4	Boundaries and interfaces	14
<b>5</b>	<b>Installation</b>	<b>15</b>
5.1	General information	15
5.2	Installation work	15
5.2.1	Installation	15
5.2.2	Connecting the incoming and outgoing lines	17
5.3	Checking the system	17
5.3.1	Pressure test with purge gas	17
5.3.2	Helium leak test	17
<b>6</b>	<b>Commissioning</b>	<b>18</b>
6.1	Preparations for commissioning	18
6.2	Procedure for commissioning	18
6.2.1	Connecting the process gas source	18
6.2.2	Flushing in the process gas to the consumer	18
<b>7</b>	<b>Operation</b>	<b>20</b>
7.1	General information on operation	20
7.2	Gas supply interruption	20
7.2.1	Interruptions to operation for less than 48 hours	20
7.2.2	Interruptions to operation for more than 48 hours	20
7.2.3	Putting the control panel into a safe condition	20
7.3	Exchanging the process gas source	21
<b>8</b>	<b>Maintenance, cleaning and repairs</b>	<b>23</b>
8.1	General information on maintenance	23
8.2	Flushing the process gas into the control panel	24
8.3	Regular maintenance work and cleaning	25

---

<b>9 Repair .....</b>	<b>26</b>
9.1 General information on repair work.....	26
9.2 Troubleshooting and fault rectification .....	27
<b>10 Decommissioning and recommissioning .....</b>	<b>28</b>
10.1 Decommissioning.....	28
10.2 Recommissioning.....	28
<b>11 Dismantling and disposal .....</b>	<b>29</b>
11.1 General information on dismantling .....	29
11.2 Returns.....	29
11.3 Disposal .....	30

# 1 Introduction

This user manual is the original user manual for the High pressure panel BM50-1+2 from Spectron Gas Control Systems GmbH, referred to as Spectron.

The user manual is intended to facilitate correct and safe operation for the operating firm, and to warn against misuse. It is intended for the qualified personnel and the operator of the facility.



## **WARNING**

### **Incorrect operation**

Incorrect operation of the system, e.g. due to instruction errors, can lead to personal injury or damage to the system.

- a) Access to the user manual by the operating and maintenance personnel must be absolutely ensured at all times.
- b) A copy of the system documentation including the user manual must therefore be kept either on the system or in a suitable and accessible location.



## **NOTICE**

### **Additional components**

At the customer's request, this product can be equipped with additional components, which deviates from the standard described. This must be considered in all sections of this user manual!

This user manual contains information protected by copyright law. It must not be photocopied, reproduced, translated or copied onto data carriers, either in full or in part, without prior authorisation. Spectron retains all further rights.

## 2 Description

### 2.1 Intended use

The intended use of the High pressure panel BM50-1+2 is the distribution of a gas from a gas source without a reduction in pressure.

High pressure panels of type BM50-1+2 are suitable for flammable gases, non-flammable gases, non-corrosive gases and for oxygen up to gas quality 6.0.

The permissible gas types and pressure ranges are each specified on the label (see "Identification / label").

The High pressure panel is equipped with a process gas valve and an exhaust gas valve on each side.

The equipment versions of the High pressure panels without electrical components may be used in an explosion hazard zone as they do not have separate ignition sources (ignition hazard assessment according to DIN EN ISO 80079-36).

High pressure panels with electrical components that are suitable for use in an explosion hazard zone are marked on the label according to EU Directive 2014/34/EU.

To be able to use the High pressure panels as intended, all persons working with them must comply with the specifications of the relevant user manual.

The area in which hazards can occur when used as intended is the area around the High pressure panels. The danger zone changes depending on the system status and use.

### 2.2 Misuse

Any improper use constitutes misuse. High pressure panels may only be used for the specified gases and in the specified pressure range. High pressure panels with electrical components without marking according to EU Directive 2014/34/EU may not be used in an explosion hazard zone.

Furthermore, the following operating conditions are regarded as misuse:

- Use for gases in their liquid phase
- Failure to carry out inspection and maintenance work
- Pressurisation in reverse (opposite to the flow direction)
- Operation with gases that are not specified on the label
- Operation outside the permissible technical limit values
- Failure to heed and comply with any applicable legal regulations and other provisions
- Non-observance of the user manual
- Failure to heed the information on the label and in the product data sheet

### 2.3 Identification / label

The label is located on the mounting plate of the High pressure panel.

The label provides the following details:

Details	Example
Project number	PROJECT
Article description	BM50-1+2 -300-M-...
Inlet pressure P1	300 bar
Gas type	GAS TYPE

## 2.4 Environment

### 2.4.1 Temperatures

Normal temperatures expected in a production area are assumed when operating the system: -20°C to +60°C.

The air humidity must be below 60 % rel. humidity to prevent condensation. The operating temperature depends on the gas used.

### 2.4.2 Degree of cleanliness

Access to the system and to the escape and rescue routes must not be blocked.

The product should be kept clean (dust-free).

A suitable purge gas must be used, taking into account the quality and properties of the process gas.

Compressed air must be used for the control air at least class 5 according to ISO 8573-1.

### 2.4.3 Emissions

The A-rated sound pressure level does not exceed the value of 70 dB(A). It is not necessary to wear hearing protection.

The waste gas line or a burst disc line must not end in areas where the escaping process gas poses a hazard to persons or the environment.

Further emissions in the form of vibrations, radiation, vapours, dusts and waste water do not occur in the regular operation of the product.

## 2.5 Standards and laws

The design and construction of the High pressure panel is subject to the following standards and directives:

2006/42/EC	Machinery Directive
2014/68/EU	Pressure Equipment Directive
2014/34/EU	ATEX directives
DIN EN ISO 12100:2010	Safety of Machinery
Safety data sheet for the gases used	Process gas and auxiliary media

Various **additional** laws, regulations and guidelines must be complied with when handling pressurised gases. Find out about the laws, regulations and guidelines that apply in your location.

BetrSichV	Betriebssicherheitsverordnung (Industrial health and safety ordinance)
ProdSG	Produktsicherheitsgesetz (Product Safety Law)
GefStoffV	Gefahrstoffverordnung (Hazardous Substances Ordinance)
TRGS 400, 407, 500, 720, 721, 722, 727, 745, 746	Technische Regeln Betriebssicherheit (Technical Regulations on Operational Safety)
TRBS 1111, 2152, 3145, 3146	Technische Regeln Betriebssicherheit (Technical Regulations on Operational Safety)
DGUV Regulation 1	German Trade Association Principles of Prevention
DGUV Rule 113-001	German Trade Association Rules on Explosion Protection

EIGA documents

## 3 Safety

### 3.1 Basic information on the safety instructions

The product complies with the recognised technical regulations. Nevertheless, knowledge of the media used and their dangers as well as basic knowledge of the pressure control panel are prerequisites for safe and accident-free operation.

The user manual must be read and understood by every user. Instruction must be documented in writing.

The safety instructions are to be regarded as a supplement to the applicable accident prevention regulations and laws. Existing accident prevention regulations and laws must be observed in all cases.



#### NOTICE

Hazards from the operating environment of the system can lead to injuries to persons.

- a) No changes may be made to the system which result in a change in function.
- b) It is not possible to outline and cover in this manual all hazards arising from the environment or unforeseeable operating conditions of the system.

In the Safety Instructions chapter:

- Users are informed regarding hazards, residual risks and measures for risk reduction.
- The presentation of the safety instructions and the symbols is explained.
- Basic safety instructions to be observed in general are listed. Specific safety instructions are listed in the relevant chapters.



#### ⚠ DANGER

**DANGER** indicates an imminent danger. If not avoided, death or extremely serious injuries will result.



#### ⚠ WARNING

**WARNING** indicates a potential imminent danger. If not avoided, death or serious injury could result.



#### ⚠ CAUTION

**CAUTION** indicates a potentially imminent danger. If not avoided, minor or moderate injury could result.



#### NOTICE

**NOTICE** indicates a potentially harmful situation. If not avoided, the system or property in its vicinity could be damaged.



## 3.2 Safety instructions

The safety instructions are to be observed by all persons working on the system. The rules and regulations for accident prevention applicable to the place of use are to be observed. The instruction of the operating and maintenance personnel on system safety must be documented.

Please pay special attention to this chapter to avoid accidents.

All measures and specifications in the safety data sheets must be implemented and observed.



### **⚠ DANGER**

#### **Gas leaks**

If gas escapes on the product, contamination of persons, fires or explosions or the displacement of atmospheric oxygen can occur! Serious or fatal injuries are possible.

- a) Do not place pipelines and fittings under mechanical stress. Never use pipelines and components as climbing aid or to secure other parts!
- b) In the event of leaks, immediately secure the affected area!
- c) Smoking and naked flame are strictly prohibited!



### **⚠ DANGER**

#### **Intended use**

Operation of the product with gases other than those specified or outside the limits may result in dangerous reactions in the system. Incorrect use poses considerable risks to operating personnel and the environment!

- a) Only use the product for gases for which it was designed.
- b) Only use the product in the specified limit values for pressure and withdrawal quantity.
- c) Usage for another type of gas or outside the limit values is prohibited and constitutes misuse.



### **⚠ DANGER**

#### **Defective product**

A defect on the product can result in unforeseeable operating conditions. Persons may be injured.

- a) The product may only be operated in technically perfect condition in compliance with all chapters of the user manual.
- b) Environmental protection laws and safety regulations must be observed.



### **⚠ WARNING**

#### **Displacement of atmospheric oxygen**

In the event of inert gas leaks, displacement of atmospheric oxygen may occur. Danger of suffocation!

- a) The operator must ensure adequate ventilation and airing in all rooms with gas installations and monitor the oxygen content.



### **⚠ WARNING**

#### **Repairs**

If the product is not used as intended, unpredictable operating conditions may occur. Serious personal injuries are possible.

- a) Repairs may not lead to a change in function. The system may not be tampered with or modified.
- b) Before each repair, the system must be depressurised and flushed through.
- c) Repairs are only permitted to be carried out by trained persons.



### **⚠ WARNING**

#### **Incorrect operation**

Incorrect operation of the system, e.g. due to instruction errors, can lead to personal injury or damage to the system.

- a) Access to the user manual by the operating and maintenance personnel must be absolutely ensured at all times.
- b) A copy of the system documentation including the user manual must therefore be kept either on the system or in a suitable and accessible location.



### **⚠ WARNING**

#### **Working on the product**

If an accident occurs when working on the product, there is a considerable risk of injury.

- a) Never work on the product unattended or unannounced.
- b) Observe the site safety rules and permission procedure.



### **⚠ WARNING**

#### **Maintenance**

Incorrect maintenance or maintenance work performed at the incorrect time can result in damage to the system or injury to persons.

- a) To avoid static charges, do not clean the product using dry cloths. Use damp cotton cloths.
- b) The maintenance intervals are to be specified by the system operator as part of its risk assessment.
- c) Observe the maintenance intervals and maintenance guidelines from the manufacturer and the applicable guidelines.
- d) Components may only be replaced by spare parts of the same design. The specifications of the component manufacturers must be complied with during installation.



### **⚠ CAUTION**

#### **Pressure relief lines**

Discharge of hazardous media at the end of a pressure relief line or exhaust air line.

- a) Pressure relief lines may not end in areas where the escaping process gas poses a hazard to persons or the environment.
- b) The position of the pressure relief line must be carefully checked taking into account the material properties, main wind direction and other conditions.



## NOTICE

### Lighting

Incorrect switching actions or confusion can occur due to inadequate lighting.

- a) Ensure sufficient lighting in accordance with the statutory regulations.

## 3.3 Emergencies and safety devices

The operational local safety regulations of the system operator, such as the alarm plan, fire safety regulations and the escape and rescue plans, apply in all cases for the operation of the High pressure panels .

When handling gases, all specifications from the safety data sheets must be followed. Local emergency services should be informed of the gases used at the site of the system.

In the event of mechanical damage, the product must be put into a safe operating condition.

## 3.4 Qualification of the operating and maintenance personnel

The intended user group is the system operator (user of the system) and the system maintenance personnel.

Every person working on the system must be familiar with the functions and dangers associated with the overall system. Instruction on the system is to be documented in writing.

Maintenance and repair work should only be carried out by specially trained personnel.

All operators, as well as personnel who regularly enter the area, must be trained on a minimum of the following topics:

- Alarm rules at the site and conduct in the event of malfunctions and leaks
- Basic functions of the product
- User manual
- System documentation incl. manufacturer documentation
- Position of the safety devices
- Safety data sheets on the process gas used
- Personal protective equipment

In addition, operators must have the requisite physical and mental skills to operate and maintain the equipment.

Persons who do not meet this requirement (e.g. visitors), must not remain alone in the overall system.

Operating personnel must use appropriate personal protective equipment for the activities to be performed and the associated environmental hazards. The operational instructions and the specifications of the employers' liability insurance associations and the safety data sheets must be complied with.

## 4 Design and function

### 4.1 Design

Illustration of the pressure control panel with gas cylinder connected

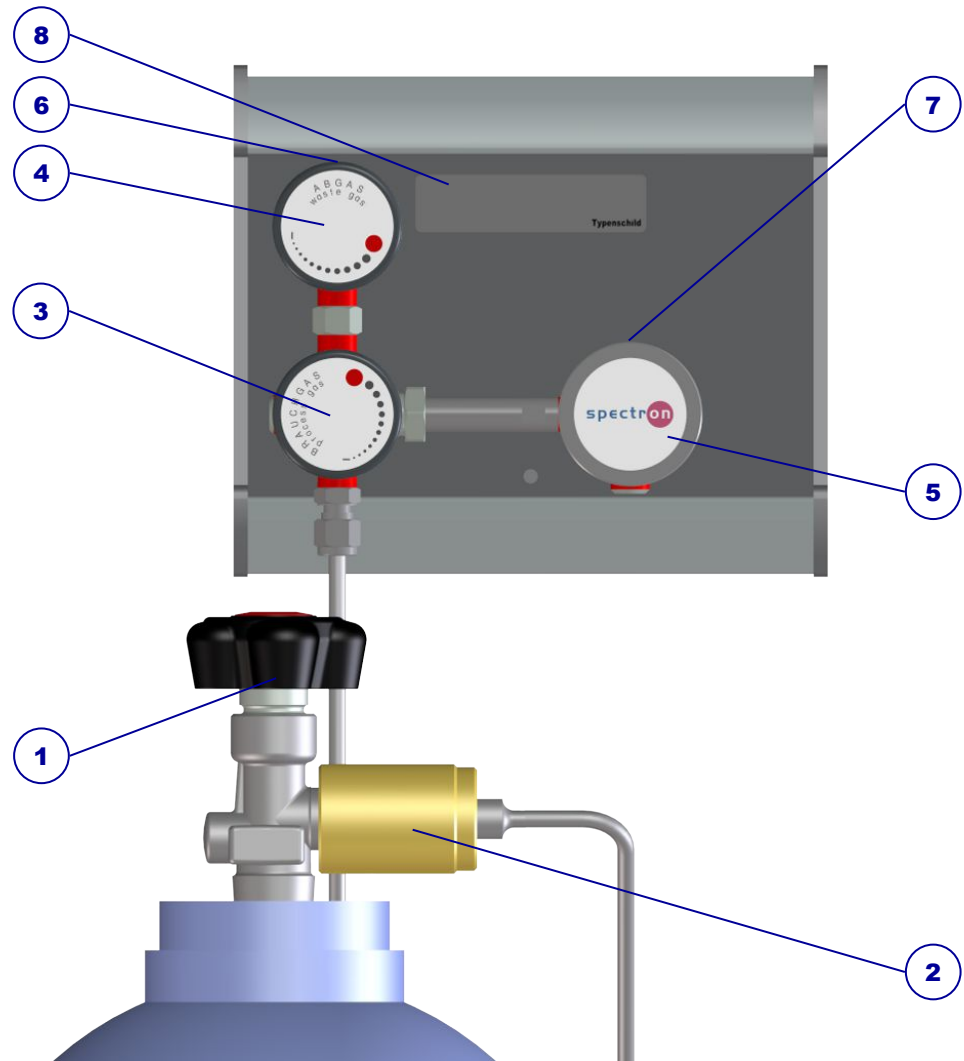

*Illustration 1: BM/BE50-1 design*

Item	Description	Short name	Connection
1	Process gas source valve		
2	Cylinder connection incl. plug		Cylinder connection (see label)
3	High-pressure process gas shut-off valve	HPI	
4	High-pressure waste gas valve	HPV	
5	Connection block	CB	
6	Waste gas connection		¼"-NPT female
7	Process gas connection		¼"-NPT female
8	Label		

## 4.2 Functional description

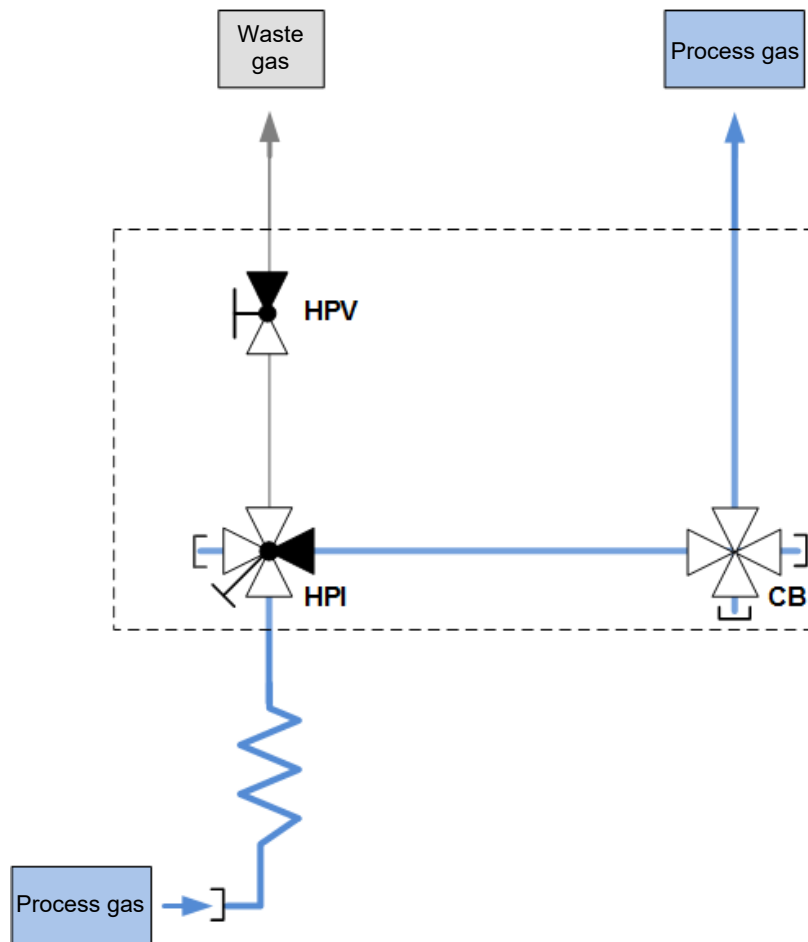

**Illustration 2: P&ID BM/BE50-1**

The intended use of the High pressure panel BM50-1+2 is the distribution of a gas from a gas source without a reduction in pressure.

With the two-sided version, the user can open and close the HPI valves on each side depending on which side is to supply the gas and which is to be the reserve side (manual switching panel).

## 4.3 Technical data



### NOTICE

The technical data can be taken from the data sheet for the relevant product. If this is not available, you can view and download it at [www.spectron.de](http://www.spectron.de).

The maximum input and output pressures and the gas type are given on the identification or label.

## 4.4 Boundaries and interfaces

The scope of supply includes the product as described in the "Design [▶ 12]" chapter. The transfer points to process gas, exhaust air and auxiliary media (incl. power supply) are the connections on the pressure control panel or product.

The following areas and functions have not been included in the scope of supply from Spectron:

- other systems, lines and installations of the overall system
- Process gas source
- Exhaust air (this applies in particular to foreseeable problems, e.g. failure of the exhaust air system)
- Supply of auxiliary media (compressed air, purge gas)
- Power supply
- Lighting
- Controller

# 5 Installation

## 5.1 General information



### ⚠ CAUTION

#### Injury or damage in the event of incorrect assembly or disassembly

Special steps are required for assembly and disassembly work on the product. Personal injuries and damage to the product are possible.

- a) Assembly and disassembly work may only be carried out by the installation engineer or appropriately skilled specialist companies and persons.
- b) The product is not permitted to be re-used following disassembly. All components must be disposed correctly.

Depending on the type of gas, different requirements apply to the installation space of gas supply systems. It is essential to observe the legal regulations and trade association regulations, and the information in the safety data sheets.

Familiarise yourself with the necessary work steps (see "Installation work [▶ 15]") and prepare the necessary tools.

#### See also

- 📖 Functional description [▶ 13]

## 5.2 Installation work

### 5.2.1 Installation

The High pressure panel can be mounted into a gas cylinder cabinet or on the room wall using C-mounting rails.



#### Step 1:

Attach the basic profile to the wall using suitable screws and dowels. The vertical distance between the centre of the basic profile and the central axis of the cylinder valve connection thread is approx. 220 mm.

Note the sticker "Top – Oben", which is attached to the inside of the basic profile and shows the correct mounting direction for the plate.



#### Step 2:

Now slide the plate with the attached fittings into the **upper** groove from below

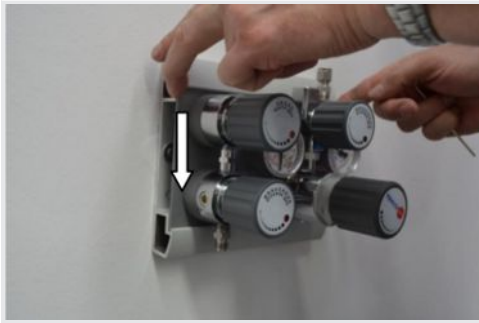
**Step 3:**

Now press the fitting plate against the basic profile and carefully slide it into the **lower** groove

**Step 4:**

Secure the fitting plate in position by tightening the grub screw.

**Step 5:**

Insert the plastic side sections into the basic profile.

**Step 6:**

Now attach the cylinder bracket to the wall at approximately 2/3 of the cylinder height and in centred position beneath the process gas valves.

**Step 7:**

Where toxic or combustible gases are used, it must be ensured that purge and venting gases are routed off safely.

For example, the corresponding lines can be connected to the waste gas valve of the pressure control panel and the relief valve of the pressure regulator via compression fittings.

The following applies to the Spectron compression fittings provided:

Insert pipes up to the end stop into the threaded fittings and tighten union nut by 1 ¼ turns.



## 5.2.2 Connecting the incoming and outgoing lines

All lines must be connected in accordance with the applicable standards and specifications and tested with purge gas (pressure test and leak test). The specifications on dimensioning of the connections are described in the "Design [▶ 12]" chapter.

1. Connect the exhaust gas outputs of the High pressure panel to the exhaust gas lines.
2. Connect the process gas output of the High pressure panel to the process.

## 5.3 Checking the system

Before beginning the test, ensure that the controller (if present) is ready for operation and is in manual mode.

### 5.3.1 Pressure test with purge gas

Inert (non-reactive) gas is used (connect to HPI) for the pressure test of the High pressure panel BM50-1+2. Ensure that the required pressure is present and there is a valve present for shutting off the purge gas (PGI).

If no PLI process gas shut-off-valve is present in the outlet of the High pressure panel, the complete line network to the process is tested and then purged. This must be carried out via an exhaust gas valve on the process. To do this, refer to the system documentation for the process.

1. Close all valves.
2. Open valves PGI and HPI to build up pressure in the system.
3. Wait until the pressure has been built up and close the PGI valve.
4. Leave the pressure for 10 minutes.
5. After 10 minutes have elapsed, check that the pressure has remained constant.
6. If there is no change, release the High pressure panel via the HPV valve and close all valves.

If the pressure has reduced, perform a leak test to check where the gas is escaping, repair the connection and repeat the pressure test. The line network can then be purged clear up to the process.

### 5.3.2 Helium leak test

A pressure test must be performed before the helium leak test. The description below assumes that the High pressure panel is in a safe condition after the Pressure test with purge gas.

1. Connect the helium leak tester to the process after the exhaust gas valve.
2. Open valves HPI and PLI.
3. Set the system under vacuum until the maximum possible value is reached (up to 5 mbar).
4. Spray joints and components with helium starting from above.

The leakage rate should be at least  $1 \times 10^{-8}$  mbar l/s He.

If the test is passed:

5. Switch off the vacuum.
6. Close the waste gas valve on the process.
7. Open valve PGI.
8. Close valve PGI.
9. Disassemble the leak test device and connect the exhaust gas line to valve HPV.
10. Close all valves.

The system should now be filled with inert gas (approx. 1 bar overpressure) up to the process.

# 6 Commissioning

## 6.1 Preparations for commissioning

Purge the armature prior to initial commissioning! It is imperative to adhere to the direction of the gas flow when doing this! You must not purge counter to the usual direction of flow (from the tapping point to the process gas source), as this can flush debris resulting from the installation work, for example, back into the armature.

The connecting threads and connecting surfaces of the gas source valves as well as the sealing rings must be checked to ensure that they are in perfect condition.

Always turn shut-off valves as far as the stop when opening or closing them.

Make sure that:

- the fittings are marked for the corresponding gas type,
- all protective caps have been removed,
- the assembly has been correctly carried out and a leak test has been performed,
- all valves are closed (the red marking is visible in the handwheel window)
- the pressure regulator has been depressurised (if possible),
- the purge gas supply (only standard for SP4 and SP6) is in operation,
- the on-site exhaust gas system is functional at all times and is in operation,
- all shut-off armatures are checked for loose connections and
- the controller is in operation.

## 6.2 Procedure for commissioning

### 6.2.1 Connecting the process gas source

Connect the pig tails. Proceed as described in the instructions for use for the respective pig tail.

The compression fitting of Spectron pig tails is pre-installed at the factory. Insert the end of the pipe with the union nut into the thread fitting of the process gas valve as far as it will go.

Now hand-tighten the union nut and then tighten by approximately 1/8 of a turn with a matching wrench. To do this, hold the screw fitting with a second wrench.

1. Place the process gas source in front of the bracket and secure with the safety chain.
2. Remove and retain the protective cap and sealing nut on the process gas source.
3. Remove the plug from the gas connection.
4. Check connection thread and sealing. A new sealing must be used for each gas source exchange.
5. Screw the gas connection onto the gas source valve by hand and tighten it gas-tight with a spanner.
6. Carry out flushing and tightness test as pressure or leak test. The HPI remains closed in this process (see "Exchanging the process gas source [▶ 21]").

### 6.2.2 Flushing in the process gas to the consumer

Flushing in the entire line network to the consumer must be implemented via a waste gas valve on the process. To do this, refer to the system documentation for the consumer. This procedure does not apply to fluorine or fluorine mixtures.

1. Close all valves.
2. Open slowly the process gas source valve and then the HPI and PLI valves, to fill the entire area in which the process gas is to penetrate up to the process and fill it (pressure build-up). The process source pressure and the gas type properties are to be taken into account here.
3. Open the shut-off valve on the consumer. Ensure that the process gas can be discharged safely via the process.

The High pressure panel is now in a condition ready for operation.

Once it is put into operation, both sides of the 2-sided panel must always be connected. Only the HPI valve on the side that is to go into operation is opened. The HPI valve on the reserve side remains closed.

# 7 Operation

## 7.1 General information on operation

During regular operation, the system will be in supply mode.

The procedure for decommissioning and recommissioning for extended system standstills is described in the "Decommissioning and recommissioning [▶ 28]" chapter.

With a High pressure panel with manual switchover, the HPI valves can be used to define which side is to supply the pressure regulator with gas. The HPI valve must be opened on this side. The other side is the reserve side. The HPI valve remains closed here.

If the reserve side is to become the supply side, the process gas source valve and HPI valve must first be closed on the supply side. The process gas source valve and the HPI valve on the reserve side are then slowly opened so that the reserve side can take over the supply. For the remaining procedure, see: "Exchanging the process gas source [▶ 21]"

## 7.2 Gas supply interruption

### 7.2.1 Interruptions to operation for less than 48 hours

For short interruptions to operation (less than 48 hours), the valve on the process gas source and valve PLI or a valve on the consumer can be closed. No other shut-off and safety measures are required.

The valve PLI may only be opened after the interruption if the indicated outlet pressure is not greater than the specified maximum outlet pressure.

### 7.2.2 Interruptions to operation for more than 48 hours

For longer interruptions to operation (over 48 hours), the following steps must be carried out:

1. Close all valves.
2. Open valve HPV to reduce the pressure.
3. Close valve HPV.

### 7.2.3 Putting the control panel into a safe condition

In the event of interruptions in operation for more than 5 days or pending maintenance or servicing, the High pressure panel must be put into a safe condition. First carry out the steps "Interruptions to operation for more than 48 hours [▶ 20]".

The process gas source must be connected during flushing (see "Connecting the process gas source [▶ 18]"). Also observe the "Preparations for commissioning" chapter.

To ensure high gas purity, pressure purging is to be performed as described below.

## 7.3 Exchanging the process gas source



### **⚠ WARNING**

#### **Gas source exchange**

If a gas source exchange is performed incorrectly, gas leakage and poisoning of persons may occur.

- a) The gas source exchange are to be carried out by trained specialist personnel and never unattended.
- b) A pressure test must be conducted after each gas source exchange.
- c) For each gas source exchange, a new seal suitable for the used gas is to be used.
- d) Wear the personal protective equipment prescribed in the risk assessment.

With each exchange of the gas source, check the connection for leaks. We strongly recommend replacing the sealing every time the gas source is exchanged. Always turn the shut-off valves slowly and as far as the stop when opening or closing them!

#### **Removing the empty process gas source:**

1. Close the process gas source valve.
2. Close valve HPI.
3. Open valve HPV to reduce the pressure.
4. Close valve HPV.
5. Disconnect the process gas source connection.
6. Mount the sealing nut on the gas source valve and protective cap on the process gas source.
7. Identify, secure and remove the empty process gas source.

#### **Connecting the new process gas source:**

8. Provide new process gas source, position in front of the bracket and secure using the safety chain.
9. Remove and retain the protective cap and screw plug.
10. Check the port thread and sealing; a new sealing must be used each time the gas source is exchanged.
11. Screw the process gas connection onto the gas source valve by hand and tighten it gastight with a spanner.
12. Open the process gas source valve, build up pressure, and close it again. Check using leak test spray whether the process gas port is leak-tight.
13. Open valve HPV to reduce the pressure.
14. Close valve HPV.
15. Open the process gas source valve to build up the pressure with purge gas (process gas).
16. Wait until the pressure has been built up and close the process gas source valve again.
17. Open valve HPV to build up the pressure and then close it again.  
Repeat steps 8 to 10 depending on the gas type at least 10 times.
18. Open the gas source valve to fill the gas connection with process gas.
19. Close the process gas source valve.
20. Open valve HPI. In the case of a two-sided High pressure panel with manual switchover, keep the HPI valve closed, and do not open it until the supply side has to be changed again.
21. Slowly open the gas source valve.

The High pressure panel is ready for supply.

# 8 Maintenance, cleaning and repairs

## 8.1 General information on maintenance



### **⚠ WARNING**

#### **Noise emission**

When working on pressurised pneumatic supply, significant noise emission can occur. Acute and chronic loss of hearing may result.

- a) Never perform work on the pressurised pneumatic supply without hearing protection.
- b) Only replace the silencers when the supply is unpressurised.



### **⚠ WARNING**

#### **Incorrect operation**

Incorrect operation of the system, e.g. due to instruction errors, can lead to personal injury or damage to the system.

- a) Access to the user manual by the operating and maintenance personnel must be absolutely ensured at all times.
- b) A copy of the system documentation including the user manual must therefore be kept either on the system or in a suitable and accessible location.



### **⚠ WARNING**

#### **Working on the product**

If an accident occurs when working on the product, there is a considerable risk of injury.

- a) Never work on the product unattended or unannounced.
- b) Observe the site safety rules and permission procedure.



### **⚠ WARNING**

#### **Maintenance**

Incorrect maintenance or maintenance work performed at the incorrect time can result in damage to the system or injury to persons.

- a) To avoid static charges, do not clean the product using dry cloths. Use damp cotton cloths.
- b) The maintenance intervals are to be specified by the system operator as part of its risk assessment.
- c) Observe the maintenance intervals and maintenance guidelines from the manufacturer and the applicable guidelines.
- d) Components may only be replaced by spare parts of the same design. The specifications of the component manufacturers must be complied with during installation.



## ⚠ CAUTION

### Injury or damage in the event of incorrect assembly or disassembly

Special steps are required for assembly and disassembly work on the product. Personal injuries and damage to the product are possible.

- a) Assembly and disassembly work may only be carried out by the installation engineer or appropriately skilled specialist companies and persons.
- b) The product is not permitted to be re-used following disassembly. All components must be disposed correctly.



## NOTICE

### Lighting

Incorrect switching actions or confusion can occur due to inadequate lighting.

- a) Ensure sufficient lighting in accordance with the statutory regulations.

Correctly performed and timely maintenance increases the service life, ensures availability and helps to avoid undesirable downtimes. Depending on the gas type, the components are subject to different maintenance intervals. Observe the stipulations from the applicable directives.

Servicing and maintenance measures are only permitted to be carried out by competent specialist companies and persons.

Maintenance work should be documented by the operator. The documentation should indicate who carried out which work and when (proof of maintenance).

It is only permitted to use original spare parts or equivalent spare parts as well as suitable tools:

- The recommended maintenance and test intervals are to be observed! (Also observe the manufacturer's documents)
- The causes of possible defects are to be investigated, e.g. damage, unusual noises, overheating etc.

Before beginning maintenance work, the pressure control panel must be flushed (see "Interruptions to operation for more than 48 hours [▶ 20]"). After completing the work, a re-commissioning process must be carried out (see "Commissioning [▶ 18]").

### See also

- 📖 Commissioning [▶ 18]
- 📖 Interruptions to operation for more than 48 hours [▶ 20]

## 8.2 Flushing the process gas into the control panel

1. Close all valves except LPV (if present).
2. Slowly open the process gas source valve and then the HPI valve to fill the entire area in which the process gas is to penetrate (pressure build-up).
3. Open valve PLI.

The process source pressure and the gas type properties are to be taken into account here.

The High pressure panel is now in a condition ready for operation.

If operation is not to be continued following the flushing process, proceed in accordance with "Gas supply interruption [▶ 20]".



## 8.3 Regular maintenance work and cleaning

For components in which the tests reveal wear or even malfunctions, repairs or component replacement must be carried out by competent specialist companies and persons.

Components	Test	Interval
Filter	Replace filter	Replacement with insufficient flow rate
All	Visual inspection for corrosion, damage and correct fastening Functional test Leakage test	At least annually and before each commissioning process
Earthing	Visual inspection for damage and correct fastening	At least annually

The product should be cleaned on a regular basis. Heavy soiling can lead to malfunctions.

Only clean the product as necessary using a damp, lint-free and clean cloth, without cleaning agent.

## 9 Repair

### 9.1 General information on repair work



#### **⚠ WARNING**

##### **Noise emission**

When working on pressurised pneumatic supply, significant noise emission can occur. Acute and chronic loss of hearing may result.

- a) Never perform work on the pressurised pneumatic supply without hearing protection.
- b) Only replace the silencers when the supply is unpressurised.



#### **⚠ WARNING**

##### **Incorrect operation**

Incorrect operation of the system, e.g. due to instruction errors, can lead to personal injury or damage to the system.

- a) Access to the user manual by the operating and maintenance personnel must be absolutely ensured at all times.
- b) A copy of the system documentation including the user manual must therefore be kept either on the system or in a suitable and accessible location.



#### **⚠ WARNING**

##### **Working on the product**

If an accident occurs when working on the product, there is a considerable risk of injury.

- a) Never work on the product unattended or unannounced.
- b) Observe the site safety rules and permission procedure.



#### **⚠ CAUTION**

##### **Injury or damage in the event of incorrect assembly or disassembly**

Special steps are required for assembly and disassembly work on the product. Personal injuries and damage to the product are possible.

- a) Assembly and disassembly work may only be carried out by the installation engineer or appropriately skilled specialist companies and persons.
- b) The product is not permitted to be re-used following disassembly. All components must be disposed correctly.



#### **NOTICE**

##### **Lighting**

Incorrect switching actions or confusion can occur due to inadequate lighting.

- a) Ensure sufficient lighting in accordance with the statutory regulations.

The objectives of the repair are:

- Detect and assess the causes of the malfunction
- Rectify faults and restore operational readiness

Repairs to the product may only be performed by the manufacturer or specialist personnel instructed on the system.

Work on electrical system parts may only be performed by a qualified electrician.

Before beginning work, the pressure control panel must be purged (see "Flushing through to the process"). After completing the work, a re-commissioning process must be carried out (see "Commissioning [▶ 18]").

#### See also

 Commissioning [▶ 18]

## 9.2 Troubleshooting and fault rectification

Fault	Possible cause	Remedy
Outlet pressure too low	Process gas source empty	Check inlet pressure on the pressure regulator and change the process gas source if necessary
Vibration noises in the pressure regulator	Pressure regulator faulty	Replace pressure regulator
Pressure regulator frozen	Flow rate too high	Reduce flow rate or use gas preheater if possible
System pressure cannot be set to the desired value	Pressure regulator faulty	Replace pressure regulator
	System pressure outside the intended system pressure	Only operate the system at the intended range
Flow insufficient or fluctuating	Inlet pressure of the process gas too low	Increase inlet pressure
	Valve faulty	Replace faulty valve
	Filter loaded	Change filter
Relief valve, over-pressure valve, safety valve or burst disc are discharging gas	Impermissible pressure rise in the outlet pressure range	Close all valves and check pressure control panel
HPI valve cannot be opened or closed	Pneumatic pressure too low	Check pneumatic pressure
	Compressed air hose ripped	Replace compressed air hose out
Leak	Connection leaking	Flush pressure control panel clear and perform pressure test and leak test

# 10 Decommissioning and recommissioning

## 10.1 Decommissioning

The gas supply via the High pressure panel can be interrupted without additional risks. No special maintenance or preservation work is required during this time.

If the High pressure panel remains unused or disassembled for an extended period, a decommissioning process must be carried out. In principle, decommissioning must be carried out in the following order:

1. Interrupt gas supply (see "Gas supply interruption [▶ 20]").
2. Disconnect the process gas source from the High pressure panel .
3. Seal all open screw connections tightly (e.g. plug on process gas port).
4. Flushing through to the process (see "Flushing through to the process").
5. Close all valves.
6. Switch off controller.

## 10.2 Recommissioning

Recommissioning of the High pressure panel must be carried out in accordance with the stipulations in the "Commissioning [▶ 18]" chapter.

# 11 Dismantling and disposal

## 11.1 General information on dismantling



### ⚠ WARNING

#### Noise emission

When working on pressurised pneumatic supply, significant noise emission can occur. Acute and chronic loss of hearing may result.

- a) Never perform work on the pressurised pneumatic supply without hearing protection.
- b) Only replace the silencers when the supply is unpressurised.



### ⚠ CAUTION

#### Injury or damage in the event of incorrect assembly or disassembly

Special steps are required for assembly and disassembly work on the product. Personal injuries and damage to the product are possible.

- a) Assembly and disassembly work may only be carried out by the installation engineer or appropriately skilled specialist companies and persons.
- b) The product is not permitted to be re-used following disassembly. All components must be disposed correctly.



### NOTICE

#### Lighting

Incorrect switching actions or confusion can occur due to inadequate lighting.

- a) Ensure sufficient lighting in accordance with the statutory regulations.

Before dismantling and disposal of the product, it must be taken out of operation and purged. The product must then be disconnected from the auxiliary media supply.

The dismantling process is to be carried out in the following order:

1. Purging of the product and decommissioning.
2. Disconnect the product from the gas supply system.
3. Disconnect the product from the process.
4. Remove the product – to do so, please refer to the "Installation [▶ 15]" chapter.
5. Seal all ports on the product.
6. Pack the product.

## 11.2 Returns

If products are returned to Spectron for checking, maintenance or repair, it is essential to purge them with inert gas. A check can only be undertaken by Spectron if the repair pre-registration including the decontamination declaration has been duly completed.

## 11.3 Disposal

Dismantling and disposal must be carried out in accordance with the official and legal requirements at the site of the system. The operator must produce a risk assessment and work instructions before dismantling. A piece of equipment may only be disposed of when the decontamination declaration has been provided, completed in full.



# Gas control on a high level



Spectron Gas Control Systems GmbH  
Monzastr. 2c  
D-63225 Langen  
Tel: +49 (0)6103 9424-050  
Fax: +49 (0)6103 9424-072  
info@spectron.de  
www.spectron.de